

Submersible mixers  
type ABS RW 200 – RW 650



# Main industries and applications

A compact and versatile mixer with a wide range of applications, including use in aggressive and abrasive liquids.

- Mixing and stirring applications in sewage treatment plants and industrial areas such as:
  - Equalization of sewage
  - Biological processes (aerobic, anoxic and anaerobic)
  - Selector (contact zone)
- Applicable for homogenization highly concentrated sludge and slurries such as:
  - Primary, secondary and digested sludge in storage and buffer tanks
  - Lime and mineral slurries
- Mixing applications in pump sumps as prevention of deposits and floating crusts (RW 200/280)
- Hazardous locations:
  - Certification for ATEX (Ex II 2G Ex h db IIB T4 Gb), FM and CSA available as an option



Water and wastewater



General industry



Pulp, paper and board

## Key customer benefits

### Economical

- The RW mixer range includes several submersible mixers with integral motors ranging from 1.3 to 13 kW (1.7 – 17.5 hp)
- Sulzer offers efficient multiple and gear-driven mixers either standard or explosion-proof motor enclosures
- Reduced energy costs
- Short mixing times

### Reliable

- Compact, water pressure-tight design
- Minimal risk of motor overloading

### Easy to replace existing installations

- Our wide range of brackets and adapters make them suitable for existing guide rails and lifting devices without modification to meet customer needs.

# RW 400 and RW 650 features and benefits

1 Efficient three-phase motor, water pressure-tight encapsulated. Protection type IP 68, stator insulation class F (155°C). Motor shaft and rotor dynamically balanced

- Economical and reliable design
- Continuous running 24/7

2 Pre-loaded upper bearing

- Prevents spinning through the design of the outer ring
- Eliminates backlash
- Ensures longer bearing life

3 DI-system

- Seal monitoring and indication that an inspection is due

4 Solids deflection ring

- Protects the mechanical seal from damage due to the ingress of solids or fibrous matter

5 Enhanced mechanical seal protection

- Keeps the mechanical seal clog-free
- Greatly extends the life of the seal

6 Hydraulic-optimized, 2- or 3-blade axial flow propeller design

- Achieves high thrust and therefore a high flow capacity
- Strong rotating flow in axial direction
- Ensures high mixing performance
- Reduces maintenance through self-cleaning

7 Abrasion-resistant, galvanically insulated mast bracket

- Reduces the risk of electrochemical corrosion

8 TCS (Thermo Control System)

- Provides a warning or switches off the motor automatically before the permissible temperature limit is exceeded, whether due to high-temperature medium or another problem source

9 Corrosion resistant execution

- Suitable for industrial applications and nitrification tanks in wastewater treatment plants

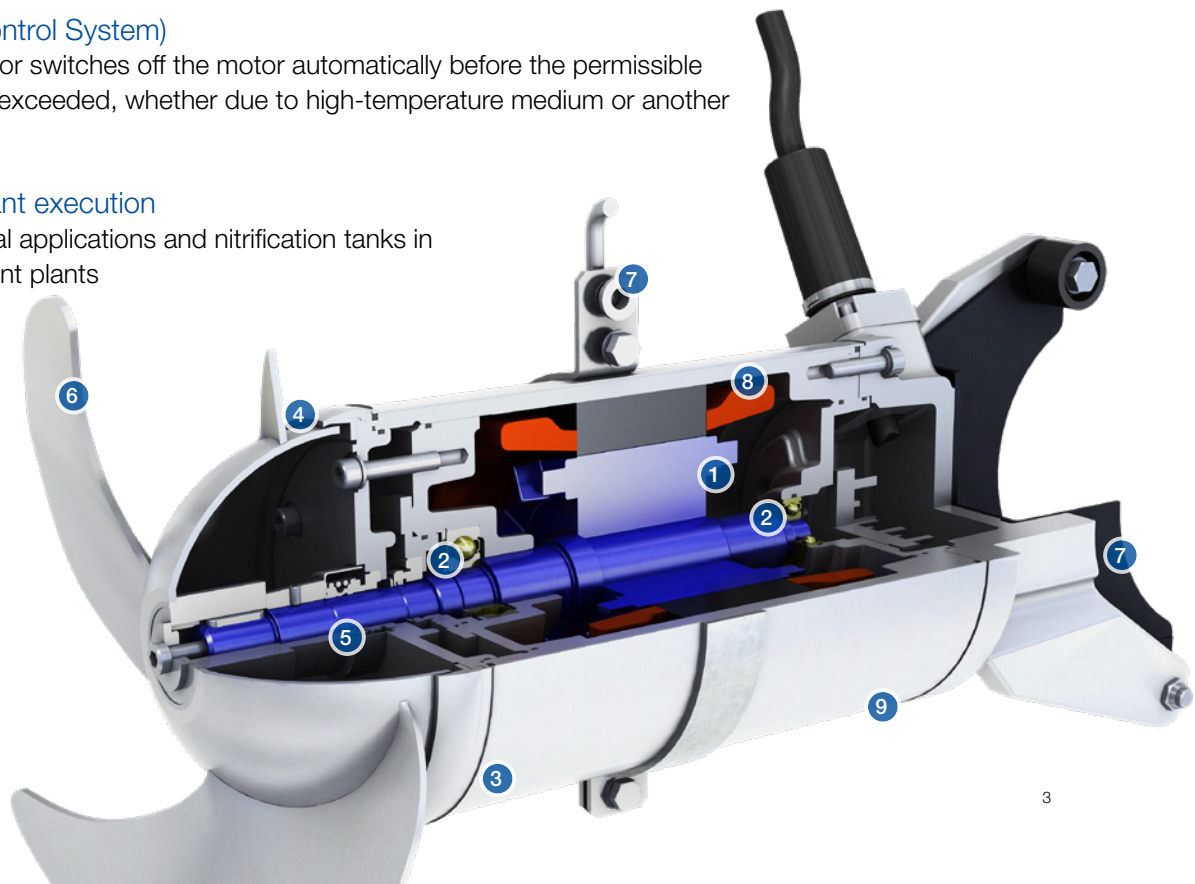

# RW 480 features and benefits

1 Efficient three-phase motor, water pressure-tight encapsulated. Protection type IP 68, stator insulation class F (155°C). Motor shaft and rotor dynamically balanced

- Economical and reliable design

2 Helical one stage robust gearbox

- Allows numerous ratios via fatigue-strength helical gears
- Calculated lifetime of more than 100'000 hours for the oil-lubricated bearings
- Compact and lightweight drives

3 Large, long-lasting bearings

- Offer true reliability with a calculated lifetime of more than 100'000 operating hours
- Need no maintenance – lubricated for life

4 DI-system

- Seal monitoring and indication that an inspection is due

5 Solids deflection ring

- Protects the mechanical seal from damage due to the ingress of solids or fibrous matter

6 Enhanced mechanical seal protection

- Keeps the mechanical seal clog-free
- Greatly extends the life of the seal

7 Special 2-blade mixed-flow propeller design

- Strong rotating turbulent flow in radial and axial direction
- Highly efficient for homogenization of concentrated sludge and slurries
- Ensures high mixing performance
- Reduces maintenance through self-cleaning

8 Abrasion-resistant, galvanically insulated mast bracket

- Reduces the risk of electrochemical corrosion

9 TCS (Thermo Control System)

- Provides a warning or switches off the motor automatically before the permissible temperature limit is exceeded, whether due to high-temperature medium or another problem source

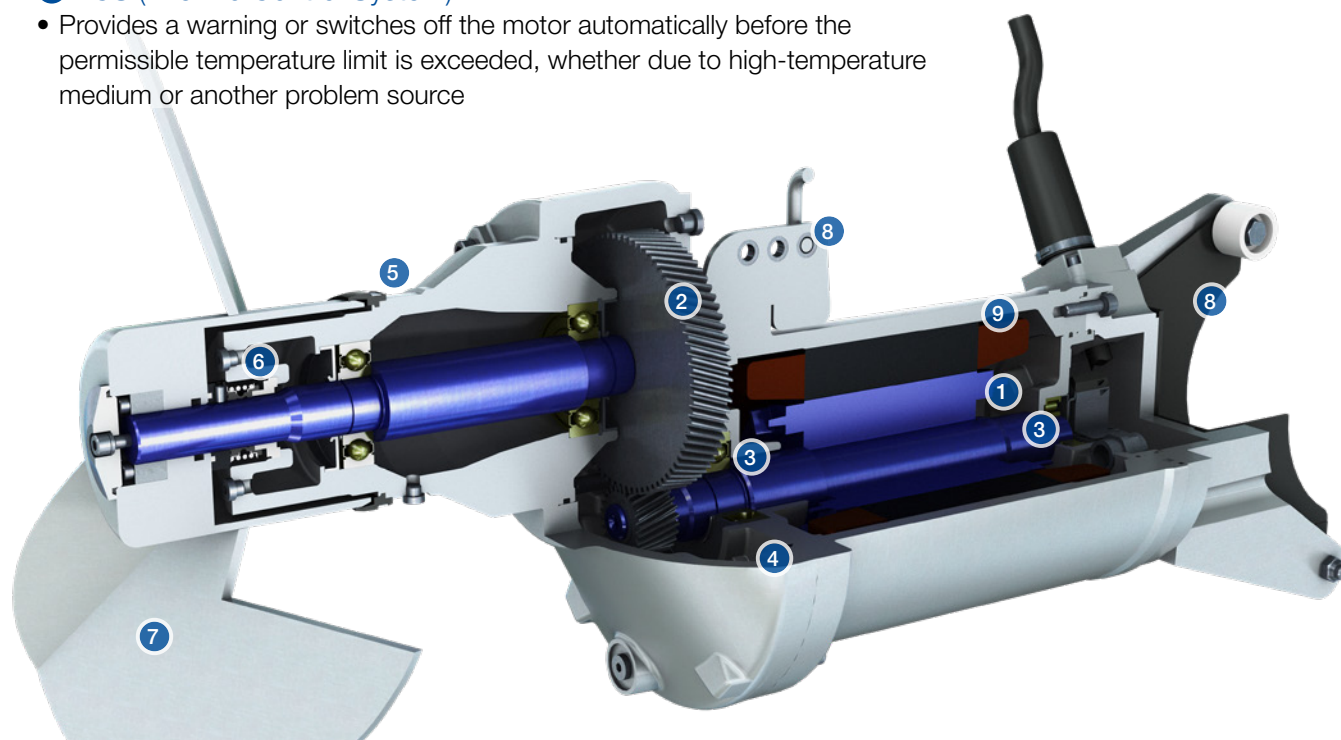

# RW 200 and RW 280 features and benefits

Prevention of deposits and floating crusts in pump sumps, it keeps the sump clean, it limits the accumulation of solids and consequently the pumps blockages. Intermittent duty when used in combination with the pumps, to reduce the power consumption.

Efficient three-phase motor, water pressure-tight encapsulated. Protection type IP 68, stator insulation class F (155°C). Motor shaft and rotor dynamically balanced

- Economical and reliable design

## DI-system

- Seal monitoring and indication that an inspection is due

## Solids deflection ring

- Protects the mechanical seal from damage due to the ingress of solids or fibrous matter

## Hydraulic-optimized, 2-blade axial flow propeller design running at high speed (4 poles)

- Strong rotating turbulent flow in axial direction
- Highly efficient for homogenization of raw sewage and floating crusts
- Ensures high mixing performance
- Reduces maintenance through self-cleaning

## TCS (Thermo Control System)

- Provides a warning or switches off the motor automatically before the permissible temperature limit is exceeded, whether due to high-temperature medium or another problem source

## Versatile mounting bracket for hanging installation

- It allows to adjust both vertical and horizontal orientation of the mixer to remove the sediments from the dead zones of the wet sump
- The hanging installation allows retrofitting the mixer in critical pumping stations even when they are in operation. The installation footprint is minimal



# RW 200 / RW 280 pump stations

The RW 200 / RW 280 mixers are mainly used for mixing applications in pump sumps. The function of the mixers is to thoroughly mix up the contents of the sump before the pumps themselves start up, so that after completion of the pumping only a small amount of deposit remains. Silting up of the pump sump is therefore effectively avoided.

In general the operation of the mixers in the pump sump is controlled as follows: The mixer is operated by a level control unit which switches it on shortly before the pumps themselves are switched on. In general a timer allows 30 to 45 seconds mixing before starting the pumps. An additional level control unit switches off the mixer while propeller coverage of 30 to 40 cm remains.

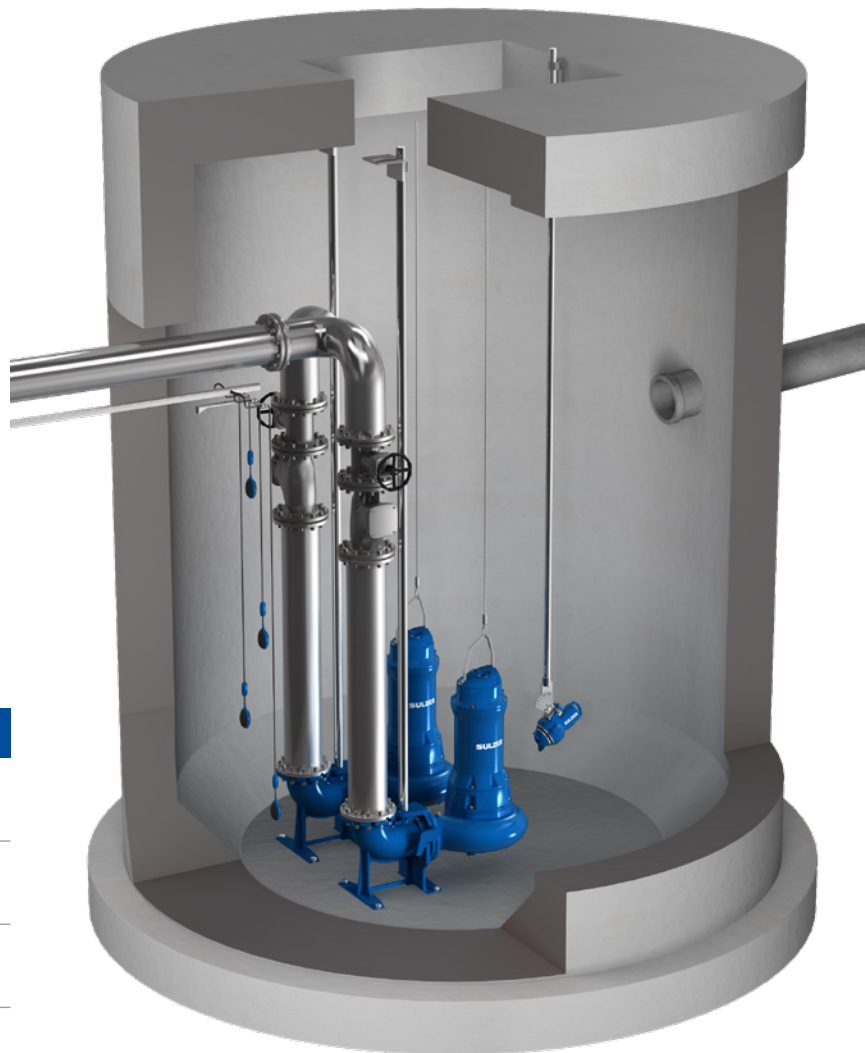

## Specific power density

Municipal raw sewage	25 - 40 W/m <sup>3</sup>
Sewage containing lots of solid materials	50 - 80 W/m <sup>3</sup>
Sewage containing lots of sandy materials	100 - 200 W/m <sup>3</sup>

## Maximum sump size when using only RW 200 / RW 280



### Round tanks

Max. diameter:  
RW 200 = 3.5 m  
RW 280 = 5.0 m



### Rectangular tanks

Max. size:  
RW 200 = 3 x 5 m  
RW 280 = 4 x 6 m

# Materials

Mixer parts RW 400 – RW 650	EC (cast iron)	CR (stainless steel)
Motor housing	EN-GJL-250, painted	1.4571 (AISI 316Ti)
Motor shaft / propeller shaft	1.4021 (AISI 420)	1.4404 (AISI 316L)
Propeller	1.4571 (AISI 316Ti)	1.4571 (AISI 316Ti)
Fasteners	1.4401 (AISI 316)	1.4401 (AISI 316)

Mixer parts RW 200 and RW 280	EC (cast iron)
Motor housing	EN-GJL-250, painted
Motor shaft / propeller shaft	1.4021 (AISI 420)
Propeller	EN-GJL-250, painted
Fasteners	1.4401 (AISI 316)

Mixer parts RW 480	EC (cast iron)
Motor housing	EN-GJL-250, painted
Motor shaft / propeller shaft	1.4021 (AISI 420) / 1.4418 (AISI -)
Propeller	1.4571 (AISI 316Ti)
Fasteners	1.4401 (AISI 316)

# Operating data

	50 Hz	60 Hz
Propeller diameter	200 - 650 mm	200 - 650 mm 7.9 - 25.6 in.
Motor power	up to 11 kW	up to 13 kW up to 17.5 hp
Motor efficiency	up to 87%	up to 88%
Mixing flow	up to 0.83 m <sup>3</sup> /s	up to 0.92 m <sup>3</sup> /s up to 14'600 USgpm



[www.sulzer.com](http://www.sulzer.com)

E10336 en 1.2020, Copyright © Sulzer Ltd 2020

This brochure is a general presentation. It does not provide any warranty or guarantee of any kind. Please, contact us for a description of the warranties and guarantees offered with our products. Directions for use and safety will be given separately. All information herein is subject to change without notice.