

Pure Filtration Solutions.

*Owner's Operation
and
Maintenance
Manual*

800 Orange Avenue, Daytona Beach FL 32114

Phone: 386/248-0500 - Fax: 386/248-3033 - Toll Free: 800/881- 0320

www.millerleaman.com



The *Turbo-Disc* Filtration System is protected by the following patent:

#6,419,826

OTHER PATENTS MAY BE PENDING.

COPYRIGHT © 2008 by Miller-Leaman, Inc.

All Rights Reserved

Miller-Leaman, Inc.

- 800 Orange Avenue • Daytona Beach, FL 32114 •
- Toll Free: 800 881-0320 • Phone: 386 248-0500 • Fax: 386 248-3033 •
- E-mail: sales@millerleaman.com • Web Site: www.millerleaman.com •

First Edition

Copyright © 2006, 2013 by Miller-Leaman, Inc. - 800 Orange Avenue, Daytona Beach, FL 32114 Printed in the United States of America. All rights reserved. This manual or parts thereof may not be reproduced in any form, mechanical, electronic, Internet, or in any form without the written permission of Miller-Leaman, Inc.

Toll Free: 800 881-0320 • Phone: 386 248-0500 • Fax: 386 248-3033

E-mail: sales@millerleaman.com • Web Site: www.millerleaman.com

CONTENTS

Use of this Manual	6
Preface	7
About the Company	8
Safety & Operational WARNINGS	9
Safety & Operational CAUTIONS	10
Wearing Personal Protective Equipment (PPE)	12
General Equipment Lockout Procedures	13
Section 1 - Introduction to Automatic Filtration	15
1.1 Definitions of Abbreviations	16
1.2 Definitions of Terms	17
1.3 Filtration Applications	18
1.4 TURBO-DISC Basic Technical data	19
Section 2 - Turbo Disc Product Identification	21
2.1 Product Identification Label	21
2.2 Turbo Disc System Component Identification	24
2.3 System Descriptions Based on Backflush Method	27
System Supplied Pressure	28
Booster System	29
Air Assist System	30
Pressure Sustaining System	31
Section 3 - Installation and Operating Instructions	33
3.1 Overview	33
3.2 Initial Installation and Set Up	34
3.3 Initial System Start Up	35
3.4 Normal System Operation	37
3.5 Cold Weather System Operation	38



CONTENTS - Continued

Section 4 - Regular Maintenance Procedures	39
4.1 Maintenance Schedule	40
4.2 Maintenance Check List	41
Section 5 - Maintenance and Inspection of Filter System Components	43
5.1 Exploded View of Filter Housing and Filter	44
5.2 Parts List of the Filter Housing and Filter	45
5.3 Housing and Cartridge Maintenance & Cleaning Instructions	46
5.4 Filter O-Rings	50
5.5 Filter Piston Actuator	51
5.6 Solenoids and Air Valves	54
5.7 Air line Override Check Valves	55
5.8 Sustaining Valves	55
5.9 Main Process Pump	57
5.10 Main Pump & Booster Pump Troubleshooting Chart	59
5.11 Checking Pump Direction of Rotation	60
5.12 Booster Pump - Inspection and Maintenance	61
5.13 The 3-way Flow Control valves - Inspection & Maintenance	63
5.14 MAXIM Filter Controller - Setup and Troubleshooting	65
5.15 Cleaning and General Maintenance	73
Section 6 - Troubleshooting	
Troubleshooting Tree - Back Flush Cycle Not Complete	74
Troubleshooting Tree - Water in the Drainage Manifold	75
Troubleshooting Tree - Too Frequent Back Flush Cycles, System Alarm	76
Section 7 - Appendix	
Turbo Disc Maintenance Work Log	78
Turbo Disc Maintenance Schedule - Spring - Summer	79
Turbo Disc Maintenance Schedule - Fall - Winter	80
Section 8 - Replacement Parts List	82
Section 9 - Engineering Drawings	84
Section 10 - Bill of Material	86
Limited Warranty	88
Important Contacts (Back Cover)	89



Miller-Leaman knows the Industrial Markets with thousands of installations and many unique applications. Our experience along with our Thompson Strainer line of filtration products, Helix HD & HS Series Filters, and our innovative Turbo-Disc Filter gives you a selection of filtration equipment that will solve your most challenging problems.

Typical Applications Include:

- Spray Nozzle Protection
- Cooling Tower Water
- Chilled Water
- Process Cooling Water (injection molding, extrusion, etc.)
- HVAC Systems (protection of heat exchanger, etc.)
- Makeup Water
- Pre-Filtration for R.O. and Other Filters
- Well Water
- Surface Water (lakes, rivers, canals, etc.)
- Intake Water / City Water Intake
- Municipal Water
- Reclaimed Water
- Wastewater
- Scrubbers
- White Water
- Gland Seal Protection
- Vacuum Pump Protection
- Golf Course / Turf Irrigation
- Landscape / Irrigation
- Agricultural Irrigation

Automatic Turbo-Disc Filter Features:

- Extremely Low Amount of Backwash Water Volume
- Automatic, Self-Cleaning System Triggered By Differential Pressure, Elapsed Time, or Manual Override
- Centrifugal Separator Action Built Into Design, Therefore Keeping Disc Media Clean Longer Before Back Flush Cycle
- Polypropylene Disc Media, Designed for a Long Service Life
- Interchangeable Color-Coded Disc Cartridge Options for Different Micron Levels of Filtration
- Modular Design with Small Footprint
- Continuous Supply of Downstream Flow, Even During Backflush Cycle
- Booster Pump Option Available for Low Pressure Applications
- No Tools Necessary to Service Disc Cartridge



Use of this Manual

Congratulations on your purchase of a *Turbo-Disc* Filtration System.

This Operations and Maintenance (O&M) Manual provides instructions on how to operate the system and carry out routine maintenance.

The objective of this manual is to provide simple, clear and complete instructions. It is backed by Miller-Leaman, Inc.'s commitment to offer superior customer support. Every effort has been made to ensure the accuracy and completeness of information in this manual.

General Information

If any of the information or procedure explanations in this manual are unclear, please contact a Miller-Leaman Service Provider for assistance.

ONLY service personnel trained in electrical and mechanical safety should undertake operation, repairs or servicing of this equipment.

If there is any concern regarding the level of training, skill or comprehension of the manual's instructions, please have the work done by a qualified operator or a Miller-Leaman representative. Failure to do so could result in injury or damage to the equipment. Common sense and good judgment are crucial to the safe and successful operation and maintenance of the *Turbo-Disc* Filtration System.

1. Read the *Warnings and Safety Precautions* and *General Equipment Lockout Procedure* in this section before operating or performing any maintenance on this equipment.
2. Read the Safety Procedures thoroughly before starting.
3. Review all warnings and cautions that accompany any procedure and review the *Warnings and Precautions* section each time you prepare to perform maintenance in the *Turbo-Disc* Filtration System.

Preface

The Evolution of Automatic Filtration:

The Automatic Turbo-Disc Filter sets the standard for reliable, high-efficiency filtration. Utilizing a stack of injection-molded polypropylene disc media, the Automatic Turbo-Disc Filter is exceptionally durable and engineered for longevity. Automatic Turbo-Disc Filter systems are designed with a modular approach, where multiple filter housings (pods) are manifolded together with stainless steel inlet/outlet manifolds. The sizing of the system is a function of the flow rate and the solids' loading in the application. The back flush cycle is rapid and precise, using a fraction of the flush water used by traditional automatic sand media filters on the market.

Quality of Disc Filtration:

Although the three-dimensional disc media is the heart of the filter, there are other principles at work. As water enters the filter housing, it passes through the Helix Element at the base of the disc cartridge. The Helix Element spins the water at a high velocity, causing heavier particles (i.e. sediment) to centrifugally spin outward, away from the disc media.

The dirty water passes through the depth of the discs, from the outside to the inside. The discs contain grooves that run radially across the surface of the discs. These grooves are precisely molded in the surface of the discs, slightly tapered from the outside to the inside. On the opposite side of the disc surface, the grooves are running in the opposite direction, therefore creating a cross-hatching of grooves across the depth of the discs.

The combination of the Helix Turbo-Element, the grooves molded in the surface of the discs, and the caking effect achieved by the depth of the media, extremely fine particulate removal is achieved.

The discs have tapered grooves that the water passes through. The discs are stacked tightly onto a cartridge frame. The entire disc cartridge fits inside an injection-molded polyamide housing (pod). Each groove alternates direction, causing a torturous path for the water. As the water passes through the grooves, extremely fine particles are trapped in the media. During backflush, the discs uniformly separate and release the contaminants from the surface of the discs.



About the Company

Miller-Leaman, Inc. was founded in 1991 by Bill Miller, Marty Shuster and Robert Leaman. Miller-Leaman manufactures three unique filtration products: a patented line of stainless steel liquid filters/strainers commonly known as the **Thompson Filter/Strainer**, the **Helix Screen/Disc Series** and the automatic **Turbo-Disc** filter. Many new custom Filtration and Ultra-Filtration systems are being added to meet the needs of our customers.

Manufacturing operations and management personnel are located in Daytona Beach, Florida in a newly renovated, state-of-the-art 52,000 square foot facility. If your ever in the area we encourage you to visit our facility for plant tour.

Miller-Leaman promotes the **Thompson** filter/strainer, **Helix Series** and the standard in disc filtration **Turbo-Disc** filter, for a variety of markets including agricultural and industrial. Miller-Leaman markets and sells the **Thompson** filter/strainer, **Helix Series** and **Turbo-Disc** products through a network of dealers, distributors, manufactures' reps and OEM's. If you are interested in becoming a distributor, please complete our response form on the distributor inquiries web page. We thank you for your interest in our innovative line of filtration systems.

Message from our Vice President, Chris Shuster



THANK YOU...for considering our innovative Turbo Disc filtration products. This manual is designed to give you all the necessary information about our Turbo Disc filtration products. If you find that you need additional information, or clarification on information that you see, please do not hesitate to contact us.

In addition to the exceptional quality of our products, customer satisfaction is our highest priority. There are many filtration manufacturers competing in our market; therefore, we will endeavor to differentiate ourselves by offering unique products backed by a dedication to customer satisfaction.

On our website, you will find extensive technical information, including 3D model drawings, product owner's manuals, and other valuable information.

Safety and Operational WARNINGS

Three types of notices are used in this manual. This section of the O&M Manual contains *Important Contacts, Warnings and Precautions* and a *Glossary of Terms*.

	<p style="text-align: center;">GENERAL WARNING</p> <p>Contains information that if not heeded, may result in personnel injury or equipment damage.</p>
	<p style="text-align: center;">ELECTRICAL HAZARD</p> <p>Because of the potential hazard from this power source, it is prudent to use LOCK OUT procedures and TAG all sources of power before performing any maintenance, cleaning or repairs on any piece of equipment. The power sources may include electrical or stored energy. Refer to the general lock out and tag procedures in this manual.</p>
<p style="text-align: center;">HIGH PRESSURE</p>	<p style="text-align: center;">SYSTEM IS UNDER PRESSURE</p> <p>Do NOT attempt to remove filter pod or pressure gauges while system is in operation.</p>
	<p style="text-align: center;">INSPECT SYSTEM PRIOR TO OPERATION</p> <p>Visually inspect the <i>Turbo-Disc Filtration System</i> on a regular basis. Never attempt to operate the system with missing or damaged parts. Contact a Miller-Leaman Service Provider for replacement parts.</p>
<p><u>NOTE:</u></p>	<p style="text-align: center;">GENERAL INFORMATION</p> <p>Contains information or provides comments to clarify instructions.</p>

Safety and Operational CAUTIONS

	CAUTION
	Informs user when care is needed to prevent equipment damage.

Always Observe the Following CAUTIONS:

- To prevent electrical shock, turn off the system power prior to any maintenance.
- The Turbo-Disc filter is rated to an absolute maximum pressure of 125 PSI. Exceeding the maximum system pressure may result in system damage or personal injury.
- If the system operating pressure can exceed the filter's maximum pressure rating or if pressure spikes may occur, install pressure relief valves of a sufficient size and volume upstream of the inlet and downstream of the outlet of the filter. They should be set to relieve pressure at 1.2 times the maximum operating pressure (not to exceed the maximum rated pressure of 125 PSI). This will help to prevent damage to the filter housing and filter cartridge if severe stoppage or water hammer occurs.
- Water hammer may occur as a result of sudden valve opening or closing. The automated opening and closing of valves during backflush may result in pressure spikes that can cause water hammer. Insure that all piping connected to the filtration system is properly secured. Installation of a pressure relief valve will also help to prevent damage to the system in the event of an extreme water hammer pressure spike.
- System design should ensure that back flow is avoided. If necessary, back flow prevention devices should be installed upstream of the inlet and downstream of the outlet to prevent back flow or vacuum effects due to pump shut-off or topographical differences.
- **This filter system is NOT freeze protected.** If there is a risk of freezing, install indoors or properly insulate the system. (see section 3.4 for additional information)



CAUTIONS continued...

- This system is designed to work optimally at the engineered specifications. Refer to the system label (located on filtration control panel) to confirm the system's design flow, pressure and power requirements. Any deviation from these specifications may result in the system's failure to operate effectively and could cause system damage.
- This system can **ONLY** filter water. Do not use any caustic or acid chemicals that can attack the metal or plastic components of the pump or filters in the system. Do not attempt to filter other fluids without approval from Miller-Leaman Inc.
- Acids used for cleaning the filter disc media may cause burns. Wear protective clothing and protective eyewear when using these materials. After cleaning, rinse the filter disc media thoroughly with clean water. Always follow the safety precautions recommended by the manufacturer of the cleaning solution.
- Never operate the unit empty or without flow for an extended period. Never run any pumps when dry.
- Connect this system only to AC power that conforms to the information on the system label as regards to voltage and voltage specification.
- De-pressurize and drain the system prior to any maintenance. To prevent equipment damage or personal injury, be sure to always relieve the water pressure from the system.
- For correct installation, follow the installation instructions in Section 3. Refer to the appropriate electrical diagram in the Appendix to confirm the wiring connection locations.

Wearing your Personal Protective Equipment (PPE)

Safety precautions are essential when any filtration equipment is involved. These precautions are necessary when using, storing and servicing your *Turbo-Disc Filtration System*. If safety precautions are overlooked or ignored, personal injury or product damage may occur.

The filtration system was designed for specific applications. It **should not** be modified and/or used for any application other than originally specified.

Always wear your Personal Protective Equipment (PPE):

- **Eye Protection Must be Worn!**

As added protection, tight fitting glasses with side shield protection must be worn at all times. Glasses such as wrap-around style are most effective.

- **Wear Ear Protection!**

The *Turbo-Disc Filtration System* does not produce a harmful level of noise, but users are cautioned that they should wear hearing protection as appropriate to protect against other noise that may be present at the filtration system location.

- **Wear Protective Gloves!**

Always wear protective gloves when working on equipment.

- **Wear Safety Boots!**

Always wear protective footwear when working on equipment.

Equipment Lockout Procedures

The following lockout procedure is a minimum requirement. Additional precautions should be taken depending on site-specific protocols. Always check with the facility manager and senior electrician for additional precautions.

Lockout and Tag Procedures

1. Locate and identify electrical supply to equipment. Identify specific breakers or disconnects that service Miller-Leaman filtration equipment. If unsure, contact the facility electrician or maintenance personnel to locate the correct electrical supply.
2. Confirm that the control panel and other electrical equipment have been locked out.
3. Double check with a multi-meter at the filtration system's electrical connection point to insure that the system has been de-energized.
4. Isolate the system by shutting off all inlet/outlet valves to the filter. The back flush drain should not be closed, but verify it is not connected to a pressurized source.
5. Drain water from the filtration system by one of following methods:
 - Manually actuate the 3-way valves to back flush mode (via the solenoids)
 - Open any drain valves located on the system manifolds
6. Disconnect and bleed air pressure from the filtration system.
7. Verify that there is not any remaining pressure in the system prior to proceeding.
8. It is now safe to work on the system. Complete all required maintenance.

After Service Work is Complete

1. Insure that all electrical equipment has been properly secured.
2. Insure that all of the filter pods and filtration components have been returned to their original position and properly fastened.
3. Remove all lockout devices and tags.
4. Reconnect the pneumatic connections.
5. Return the filtration system online by opening the isolation valves. Slowly open the inlet valve followed by the outlet valve.
6. Turn on the controller and other electrical devices.
7. Insure that the system is online and functioning properly.

See Section 4 for more details on system maintenance.

This page intentionally left blank.

Section 1 - Introduction to Automatic Filtration

This manual was written assuming the reader has only limited knowledge of automatic filter systems. Therefore, the filter manual has been divided up into several major sections to illustrate and to give the user the knowledge to troubleshoot and repair Miller-Leaman automatic filter systems. It is expected that the user have at least a basic understanding of mechanics and electronics.

However, even in these cases the explanations in the manual will guide the user through the process of disassembly, cleaning and repairing of all of the basic maintenance items involved with automatic filter systems. Through the use of numerous graphics and illustrations the user will be able to quickly find the problem and fix the filter to get it back on line.

The first part of this chapter will outline the basic parts of the automatic filter system. These illustration while general, will allow the user to quickly identify the part, its name and description, how it works and how to get it cleaned or repaired. In many cases, an inoperative filter only needs preventative maintenance and periodic cleaning of the filter elements.

Please read and try to identify the basic parts and assemblies of the filter system before attempting maintenance or repair. Once an understanding of how the filter system works and what the automatic control features actually do, can the user find the problem and get the filter back on line.

This chapter will start out by identifying the different parts and assemblies of an automatic filter system. While there are many possible setups, depending on your filter unit, they all use the same basic assemblies: Motor and pumps, supply and discharge manifolds, filter pods and electronic controls for the different valves.

1.1 Definitions of abbreviations

The list below defines some of the words and abbreviations used in the automatic filter system. Some words and definitions are commonly used in the water filter industry, and some are used only on Miller-Leaman filter systems.

CFM - Cubic Feet per Minute

GPM - US Gallons per Minute

O&M - Operations & Maintenance

PD - Pressure Differential

ppm - parts per million

psi - pounds per square inch

TEFC - Totally Enclosed Fan Cooled (as relating to pump motors)

TSS - Total Suspended Solids

1.2 Definitions of terms

Air override -	A feature that injects compressed air into the top of the filter in order to drain water from the filter pod during back flush.
Air-assist -	A method of using compressed air and water to back flush the filter.
Back-flow -	Water flowing in the opposite direction of the design flow direction
Back flush -	The process of flowing water in the reverse direction through a filter in order to clean the filter element
Booster pump -	A pump that increases the water pressure in order to sufficiently back flush the filter
Chemical bath -	A diluted ratio of a cleaning chemical to water (for example a 5% acid bath solution to 95% water)
Controller -	A mechanism used to regulate or guide the operation of a machine, apparatus or system
Debris -	The remains of something broken down or an accumulation of fragments. For example the particulate matter found in a water sample.
Inlet pressure -	The pressure at the system's inlet manifold (for the purposes of this manual, the pressure at the inlet side of the <i>Turbo-Disc Filter</i>)
Manifold -	A pipe fitting with several lateral outlets for connecting one pipe with others
Outlet pressure -	The pressure in the system's outlet manifold (after the filters)
Pressure relief valve	A valve that will release and open when the system pressure exceeds a predetermined safe limit.
Main process pump	A pump that provides flow of water through the filter system
Supply pressure -	The pressure provided to the filter system. (often the same as the inlet pressure, unless the <i>Turbo-Disc Filter</i> includes a process (main) pump)
Throttling valve -	A valve (generally located on the outlet side of the system) used to control the flow rate going through the system
Turbidity -	A measurement of the amount of suspended solids within water. This number is based on the amount of light that can pass through the water as measured by a turbidimeter.
Water hammer -	A rapid change in pressure caused by a rapid change in velocity

1.3 Filtration Applications

Turbo-Disc Filter systems are used in a variety of markets. The following list describes some of the more common markets.

End Use	Industry	Application
<i>Cooling Water</i>	HVAC, Plastics, Textiles, Metal	Heat exchanger protection, nozzle protection
<i>Irrigation</i>	Agriculture, Landscape, Municipal Irrigation	Nozzle protection for sprinklers
<i>Process Water</i>	Municipal, Plastic, Textiles, Electronics, Food & Beverage	Nozzle protections, pre-filtration for membranes and other media filters
<i>Waste Water</i>	Municipal, Plastic, Textiles, Electronics, Food & Beverage	Nozzle protections, pre-filtration for membranes and other media filters

System Sizing

The quality and quantity of influent water can vary greatly from one application to another. The filtration goal may also vary for different applications. These items dictate the sizing of a Turbo-Disc system. Turbo-Disc systems are typically sized based on the following data:

- Required flow rate or flow range.
- Influent water quality / solids loading (TSS, turbidity, etc)
- Water quality goal (micron size, TSS, or turbidity)
- Other factors that may include Temperature, pH, and specific properties of particles being filtered.

While all of the data above is considered in properly sizing a Turbo-Disc System, the technical experience of a Miller-Leaman Representative is often the best tool. A representative who has experience with similar applications can greatly assist in the system specification.

Filter Micron Ratings

Turbo-Disc filters are offered in a variety of micron ratings. This is a nominal rating determined based on the geometry of discs and from gathered test data. It is possible for some particles greater than the filter's rating to pass through. However, test data has shown many particles smaller than the filter's rating are captured.



This increased filtration ability is often referred to as the “caking effect”. As particles are captured within the discs, the open area within each water flow path is reduced. As particles continue to be captured, the micron efficiency of the filter increases. Smaller micron particles then become trapped within the disc channels.

The performance of the discs can vary depending on the properties of the media being filtered. Softer particulate are more likely to extrude and may be able to change shape in order to pass through the filter. The depth of the Turbo-Disc media is designed to minimize the amount of possible particle extrusion. Harder particulate cannot easily change shape and are much easier to capture. In addition, the incoming water could contain particles in a range of micron sizes, and often mixed with both organic (algae and microbes) and inorganic (sand and silt) particles that need considered in the filter selection process.

1.4 Turbo Disc - Basic Technical Data

Filter Flow Rates

Turbo-Disc Filter systems are typically comprised of a manifold of Turbo-Disc filter pods. The maximum flow rate of the system is based upon the amount of filter pods, the disc micron rating, and the influent water quality. Miller-Leaman has developed test data for the maximum recommended flow per filter cartridge based upon the micron rating. However this flow rating may be reduced depending upon the influent water quality.

Filter Pressure Loss

As flow rate through each filter increases, the pressure loss will also increase. Lower micron discs will have a greater pressure loss due to the smaller flow paths through the disc media. Miller-Leaman has developed test data for the “clean” filter pressure loss based on the flow rate per filter pod. Note that these figures represent the pressure loss across the filter only. Other pressure losses that need to be included are those in the system’s piping and valves.

Other Filter Technical Information / Ratings

Permissible Temperature Range:	40 to 140 degrees F
Maximum Pressure:	125 PSI
Permissible pH Range:	4 to 10
Minimum Required Backflush Pressure:	60 PSI
Square Inches of Surface Area per pod:	231 sq. in.
Materials of Construction - Housing:	Polyamide

This page intentionally left blank.

Section 2 - TURBO DISC Product Identification

2.1 Product Identification label

Each Turbo-Disc System ships fully tested and documented. A System Identification Label is located on the system (see Fig. 1). The label provides key information required for system operation as discussed below.

MILLER-LEAMAN
INCORPORATED
800-881-0320



Serial Number	TD-00001
Model Number	B1-ATD2(6)x6-130M-A
Design Flow	375 GPM @ 35 PSI
Max Pressure	125 PSI
Power	Electrical: 460 VAC/ 3 Phase/ 60 Hz/ 4A
Requirements	Air: 4 CFM @ 80-100 PSI
Air Settings	Main regulator / filter: 80 PSI Secondary regulator: 25 PSI

Figure 1 System Identification Label

Serial Number

The serial number is assigned by Miller-Leaman in order to track system information. This number is the primary identifier to track all details on the system including test data, warranty information, technical phone calls, etc. Always keep record of this number, as it allows for quick tracking of the system should any technical support be required.

Model Number

The model number identifies the type of system and its components. Please reference the “Model Number Identification Chart” on the following page for a detailed breakdown.

Design Flow

Each system is designed for a specific flow rate and pressure. The definition of the flow and pressure specification can vary depending upon how the water flow is provided.

- **If a process (main) pump is included with the system:** The provided number is a function of the flow curve from the system’s process pump. The outlet control valve should be “throttled” until the inlet manifold pressure matches the specified pressure on the design flow. Note that the identified pressure does not consider any incoming pressure to the pump.
- **If a process (main) pump is not included with the system (customer provided flow):** The Design Flow is based on specifications identified by the customer during the approval process. It is imperative that the customer provide the proper flow and pressure as identified. Providing too much pressure or flow may result in damage to the system. Providing too little flow or pressure may result in poor backflushing of the filters.



The flow capacity of the system can greatly depend upon the influent water quality. If the actual flow does not closely follow the design flow rate or pressure, please contact a Miller-Leaman Technical Representative.

Maximum Pressure

This indicates the maximum pressure allowed within the system. Exceeding this pressure in any situation may cause severe injury to operators and damage to the system. Note that the maximum allowed influent pressure may be less than the Max Pressure, since the pressure may increase during backflush (due to a pressure sustaining valve or booster pump).

Power Requirements

In order for the system to operate, power must be provided to the system as identified on the label. This includes the required electricity (voltage/phase/frequency/amperes). If compressed air is required, the minimum CFM and pressure range will be indicated on the label.

Air Settings

Compressed air is typically used to open/close valves and to assist the backflush process. The air regulators provided on the system should be set to the specifications listed on the label. On systems with the “air-override” feature, the secondary regulator can only be set when the air-override is on during the backflush cycle (since the regulator is located after the solenoid valve).

Each *Turbo-Disc* Filtration System has been designed for specific filtration applications. Further information regarding each system’s specific applications can be derived from the system model number. This number is located on the system’s product specification, packing list, and the System Identification Label. The System Identification Label is located on the Important Contacts page of this guide and on the front of the system’s control panel



Turbo-Disc Filtration System Model Number Identification

XX	Backflush Method	No Symbol = Sufficient backflush	AA = Air-Assist System	B1, B1H, B2, B2H = Booster System
-				
ATD (#)	Filter Size; Number of Filter Pods		ATD2= 2" inlet/outlet Filter Body & Disc Stack; (#) = number of Filter Bodies in the system	ATD3= 3" inlet/outlet Filter Body & Disc Stack; (#) = number of Filter Bodies in the system
-				
#	Mainline Pipe Size		# = 2, 3 4, 6, 8, 10, 12	
-				
XXXM	Micron Rating		XXXM = 50, 100, 130, 200	
-				
PXXX	Pump Flow Rate	No Symbol = Process Pump not included	PXXX = 70-2000 GPM	
-				
SX	Sustaining Valve	No Symbol = Sustaining Valve not included	S3, S4, S6, S8 = 3" - 8" pressure sustaining valve	
-				
AX	Air Option	No Symbol = Air Override Feature not included	A = Air Override Feature; Compressed Air Required	AC = Air Override Feature; Air Compressor mounted on
-				
MODX	Modifications	No Symbol = Standard System	MODX = Any customer specific non -standard modifications	

2.2 Turbo Disc System Component Identification

Miller-Leaman, Inc. offers many configurations and options with the *Turbo-Disc* Filtration System. Each system is specifically designed to meet the customer's filtration needs. For more detailed product information, please refer to the system's product specification and other sections of the *Turbo-Disc* System Owner's Manual.

The following are descriptions of the primary components of a *Turbo-Disc* Filtration System:

Filter Housing/Pod

The filter housings contain the filter cartridges. These connect to the inlet and outlet manifolds, typically using a series of 3-way flow control valves. The number of pods required for a specific system is determined by the flow rate, influent water quality, and the desired effluent water quality. The manifold arrangement of the filter housings allow for back flushing the filters sequentially. This is the most efficient method to assure consistent results with the least amount of water usage.

Filter Cartridge

The heart of the Turbo-Disc Filter is the patent-pending filter cartridge. The filter cartridge is comprised of a vertical stack of grooved rings/discs and the frame that holds the discs in place. This frame also contains the *Helix Element*, disc cap, check valve, and backflush posts that enable automatic cleaning of the discs.

3-Way Backflush Valves

The 3-way valves are located between the filter housing and the manifolds. In order to back flush the filters, the 3-way valves are actuated to redirect flow paths between the inlet and outlet water manifolds. This allows the flow of water to be reversed through the filter, sending pressurized filtered water through the filter post nozzles and out to the back flush drain. The valves are actuated by the solenoids which are triggered by the controller.

Backflush Controller

The back flush controller monitors and operates the back flush cycle as required by the system. The controller can initiate a back flush cycle by pressure differential (between the inlet and outlet manifolds), time, or a manually by an operator. All of the critical back flush parameters are user adjustable with the menu-screens. Please reference the controller owner's manual for detailed operating instructions.

Inlet and Outlet Manifolds

The inlet and outlet manifolds direct the flow of water to and from the filter housings. These manifolds direct influent water into the filter housings and direct filtered water from the filter housings to the outlet. The manifolds are typically constructed of type 304 Stainless Steel. Optional construction materials include 316 Stainless Steel, HD Polyethylene and PVC.

Backflush Manifold

The backflush manifold directs backflush water from the filter housing to drain. The discharge for this manifold should always be to atmosphere pressure. Never plumb the discharge against pressure or a vertical rise. This will seriously reduce backflush performance.

Booster Pump / Booster Manifold (optional - booster systems)

Booster systems utilize a *booster pump* in order to increase the pressure of the filter being back flushed. A booster pump takes filtered water from the outlet manifold and increases the pressure into the *booster manifold*. This water is then used to back flush the filter(s) at a higher pressure.

Process (Main) Pump (optional)

A process pump may be included as part of any system to generate flow. This pump is sized specifically for the system and is designed to generate sufficient pressure for back flush (often in combination with a sustaining valve or booster pump).

Flow Control Valve (optional)

Many systems include a flow control valve on the outlet manifold. This may be a simple butterfly or gate valve to “throttle” the flow of water through the system. Some systems utilize pressure sustaining valves to guarantee sufficient back flush pressure.

Solenoids

The air solenoids provide actuation to each of the 3-way flow valves during back flush, using the computer controlled *Back Flush Controller*. The solenoids typically switch compressed air in order to open and close the 3-way flow control valves. Some valves may use water pressure for actuation instead of compressed air. Where compressed air is used, the solenoids should be provided with clean compressed air that is regulated to the specified pressure. Most solenoids contain manual override levers or buttons that allow the user to individually actuate filters into backflush for testing and troubleshooting purposes. These should be used only during troubleshooting or maintenance and should never be left in the actuated position.

Figure 25 - Typical Turbo Disc System Components

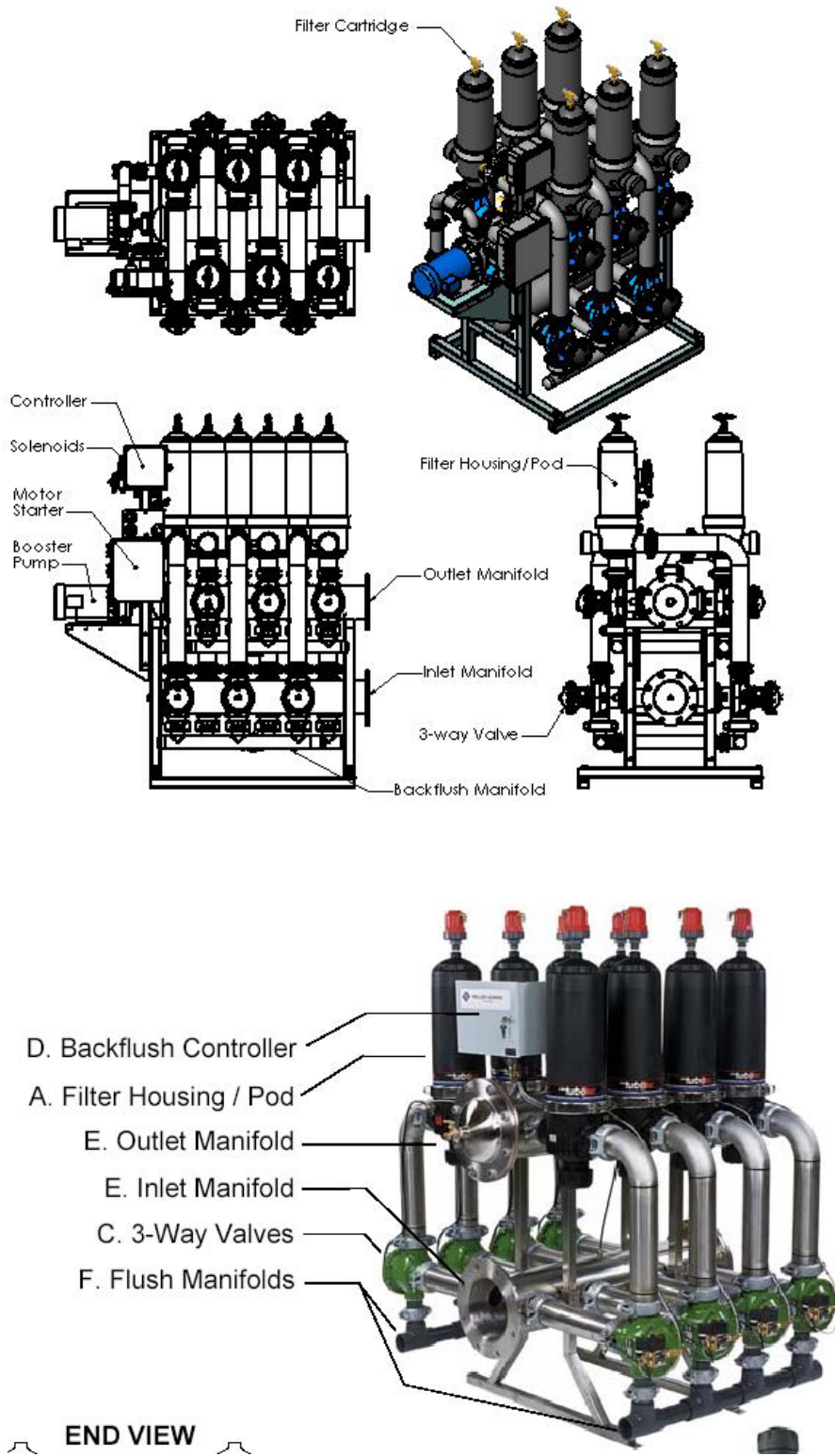

Illustrations from Training Short Version.pdf

2.3 System Descriptions Based on Backflush Methods

Turbo-Disc Filtration System's are offered in a variety of configurations. These systems can be discussed based on the method of back flush. Except for the Air Assist model, all Turbo-Disc filter cartridges require 60 psi or more in order to back flush effectively. In some situations, when this pressure is not adequate, and other means such as an air assist or booster pump system may be required to generate sufficient pressure.

Note that all of the configurations may come with or without a process (main) pump. Please review the following descriptions to understand how your system operates and how the required back flush pressure is achieved.

System Supplied Pressure System is used only for sites where the provided system pressure at the filtration site exceeds the required back flush pressure, and where a standard manifold of filters is typically sufficient. This system includes inlet, outlet, and back flush manifolds. Each filter loop contains a 3-way valve to re-direct the water flow during back flush.

Booster Systems are ideal for higher flow situations where the process pump or provided system pressure is not adequate for back flushing the filters. Booster systems are designed to filter at the provided system (influent) pressure, but require a booster pump to operate during the back flush mode to increase the pressure only to the filter(s) that are back flushing. The purpose of this type of system is to produce adequate pressure for the backwash cycle with a relatively small pump that only operates for short periods of time.

Automatic Turbo Disc Single Pod Air-Assist (SPAA) utilizes an air accumulator tank and a water reservoir. When the system goes into backwash mode the pressurized air and the water stored in the reservoir combine to create a powerful, high-pressure backwash through the discs. This eliminates the need for an external water source and guarantees efficient filter cleaning.

Pressure Sustaining System utilizes a variable flow control valve on the outlet manifold to "sustain" sufficient back flush pressure based on the pump capacity. This may reduce or shut off the downstream outlet manifold flow during back flush. Some valves may also include a throttling stem to regulate or maintain the design flow during normal filtration. This valve then closes during the back flush mode to generate the required back flush pressure to clean the filters. Note that the throttling stem should not require any adjustment from its factory setting: it is part of the system design and should not be changed.

System Supplied Pressure

For sites where the provided system pressure exceeds the required back flush pressure, and where a standard manifold of filters is sufficient. This includes inlet, outlet, and back flush manifolds. Each filter loop contains a 3-way valve to re-direct flow during back flush.

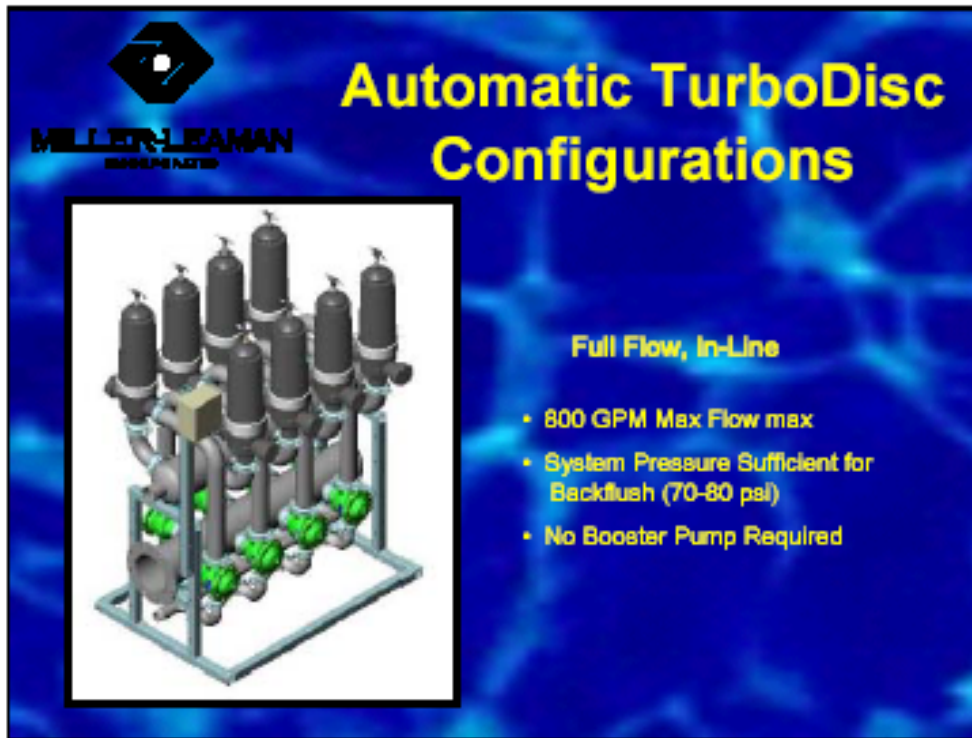

Illustrations from Training Short Version.pdf

System Operation Modes:

- A) Filtration Mode as described previously
- B) Backwash Mode is initiated by pressure differential, timer or manually by the controller. When the controller is energized to start a backwash cycle all the filters consecutively backwash either one or two filters at a time.

Booster System

Booster Systems are ideal for higher flow situations where the process pump or provided pressure is not adequate for back flushing the filters. Booster systems are designed to filter at the provided influent pressure, while a booster pump turns on during back flush to increase the pressure only to the filter(s) that are back flushing. The advantage of this type of system is that it will produce adequate pressure during the back flush cycle with a relatively small pump that only operates for short periods of time. The booster pump is sized according to conditions of the main system; primarily the flow and pressure that are supplied to the filter system.

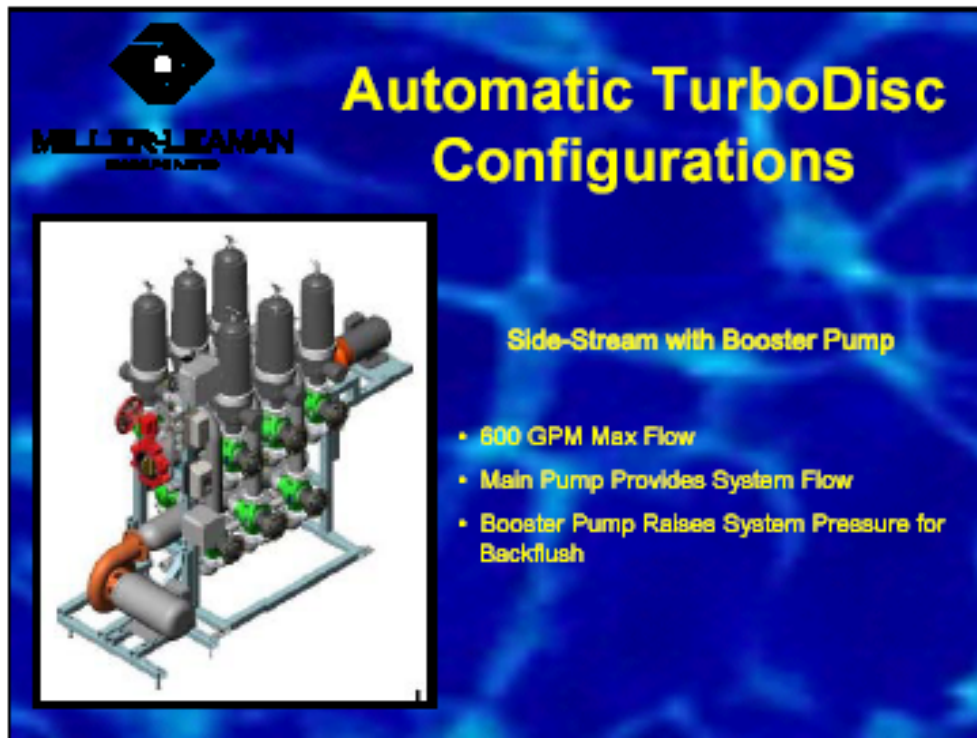

Illustrations from Training Short Version.pdf

System Operation Modes:

- Filtration Mode as described previously
- Backwash Mode is initiated by pressure differential, timer or manually by the controller. When the controller is energized to start a backwash cycle all the filters consecutively backwash either one or two filters at a time. The booster pump is actuated by a relay that is wired to a master "Hand - Auto" switch in the controller that will automatically run when the electronic controller initiates a back flush cycle.

Air-Assist System

Automatic Turbo Disc Single Pod Air-Assist (SPAA) utilizes an air accumulator tank and a water reservoir. When the system goes into backwash mode the pressurized air and the water stored in the reservoir combine to create a powerful, high-pressure backwash through the discs. This eliminates the need for an external water source and guarantees efficient filter cleaning.



Illustrations from Training Short Version.pdf

System Operation Modes:

- A) Filtration Mode water is supplied to the system at the design flow rate not to exceed 70 GPM and at a pressure not to exceed 125 PSI. The PVC gate valve at the discharge of the system must be throttled until the system pressure is the same as the design pressure. As the filter produces “clean” water the water reservoir fills with the filtered water.
- B) Back flush mode is initiated by pressure differential pressure, timer or manually. The two flow control valves are activated 5 seconds before the air injection valve opens. This isolates the pump and discharge before from the filter for the duration of the back flush. During this time the pump is running at the shut-off head. The stored air and “clean” water are forced through the filter cartridge in reverse causing the debris to exit via the backwash drain. Once filtration is resumed the recharge solenoid is energized for 15 seconds allowing the water reservoir to vent the trapped air and again fill with clean water.

Pressure Sustaining System

Utilizes a variable flow control valve on the outlet manifold to “sustain” sufficient back flush pressure based on the pump capacity. This may reduce or shut off the down stream outlet manifold flow during back flush. Some valves may also include a throttling stem to regulate or maintain the design flow during normal filtration. This valve then closes during the back flush mode to generate the required back flush pressure to clean the filters. The system is a complete package of filters, valves, pumps and solenoids and controller mounted on a single frame that can easily be installed to filter water from a reservoir or sump typically not under pressure.



System Operation Modes:

- A) Filtration Mode water is supplied to the system at the design flow rate. The design conditions are achieved by throttling the discharge valve until the system pressure is the same as the design pressure. The systems usually have a green colored flow control valve with a mechanical throttling stem. This valve closes slightly to restrict the outlet flow and thereby maintains the system pressure.
- B) Back flush mode is initiated by a differential pressure gauge, an internal timer or manually. When the controller initiates the start of a back flush cycle, the filters will sequentially back flush one at a time. During the cycle a 3-way flow control valve is activated to cut off the system flow thereby increasing the back pressure on the filters being back flushed.
- Alternately, if the system is equipped with a outlet flow shut off valve, this valve will close completely during back flush to generate as much pressure as possible by the pump. Further, if the system is equipped with a flow restrictor valve, this valve will only activate partially to generate adequate pressure. This type valve has an integral pilot valve that regulates the design flow

This page intentionally left blank.

Section 3 - Installation and Operating Instructions

Installation and operation of the Turbo Disc system

3.1 Overview

- Before installing the *Turbo-Disc* Filtration System, make sure the filter is placed on a firm and level supporting surface. Failure to do this may cause stress on the weld joints. Miller-Leaman recommends that a concrete pad be poured for the filter frame to rest on.
- Be sure that a quick response pressure relief valve has been installed upstream of the inlet and downstream of the outlet of the filter system. It should be set to relieve pressure at 1.2 times the maximum operating pressure, but never higher than the filter's absolute maximum pressure of 125psi. This is to prevent damage to the filter if severe clogging or water hammer occurs. Pressure relief valves are available in various sizes, consult your local distributor or valve manufacturer to obtain the proper valve for your application.
- The *Turbo-Disc* Filtration System requires 60 psi of downstream pressure to properly back flush. If downstream pressure is less than 60 psi then a booster pump may be required.

3.2 Initial Installation and Set-Up

- **Mechanical Connections:**

Connect the inlet, outlet and back flush manifolds in a secure method to the system. Follow the labels and flow direction arrows on the filters to make sure the system is properly connected for flow. The back flush drain (typically 2" NPT (m) connection) should be plumbed to drain to atmosphere. A restriction in this line, or any elevation in this line, will prevent the filters from back flushing properly.

The Back flush drain line requires a 2" minimum connection, draining to atmosphere. Should two, 2" Back flush drain lines be plumbed together, a 3" minimum connection, draining to atmosphere is required. NEVER put a valve in the back flush drain line.

The Pump suction inlet supply should be at least one pipe size larger than the pump suction connection size. Refer to the pump manufactures Installation, Operation and Maintenance manual for supply line connection requirements and setup.

Recommended: Isolation valves on the inlet and outlet manifolds

- **Electrical Connections:**

Connect power to the required components on your system, making sure the correct voltage and amperage is supplied. Systems containing a pump typically require 460 VAC (standard 3-phase) and must be hard wired. Make sure that any pump is rotating in the correct direction (clockwise when looking at the back of the motor). The Controller requires 115 VAC. However, systems with a single point electrical connection only require a power supply that matches the pump's voltage. Refer to the System Identification Label for system specific electrical requirements.

- **Compressed Air Connections:**

Unless an air compressor is provided, the *Turbo-Disc* Filtration System requires a compressed air supply to pneumatically operate the system's valves and air override for backflush. Connect a supply line to the standard 1/4" male air connector that is provided on the system. The typical air requirement is 80-120psi @ 4 CFM. Please see the System Identification Label for system specific air requirements. It is recommended that an air-dryer be installed for systems located in high humidity environments.

3.3 Initial System Start-Up

For an initial start-up or a seasonal restart, follow the procedure below:

Before pressurizing the system, ensure that the cartridge covers are securely fastened and the band-clamps are securely latched. Also, check for any components that may have been damaged or disconnected during installation/transit.

1. **Check the impeller rotation on the pump(s)** to verify that the impeller is rotating in the correct direction by briefly bumping the starter switch on. When looking at the back end of the pump (where fan is located) the impeller should be rotating clockwise. If it is not, then two of the three power lines wired into the starter must be switched. Make sure all power is disconnected before opening the starter. Consult a qualified electrician to adjust these wires. If the flow and pressure are achieved according to the pump performance curve, then the direction is correct.
2. **Air pressure:** If the system does not include an air compressor, then connect an air supply line to the standard 1/4" male air fitting located on the solenoid assembly. The regulator at the air hook-up point should be set about 10psi above the system's maximum water pressure. Typical settings are between 80-120psi, but must never exceed 150psi. If the air pressure regulator is set below the systems design operating pressure, the valves will not close and therefore not back flush the filters.

If your system contains a sustaining valve, the regulator should be set about 10psi above the pump's pressure when the sustaining valve is shut (this is the "dead head" pressure). There is also an air-override regulator located on the control post either above the gauges or above the electronic controller. This should be set between 15-30psi. This can be set during a back flush when air is being injected into the tops of the filter pods. It is important to the efficiency of the back flush that the air-override pressure is present and regulated to about 30 psi.

3. **Controller Settings:** Prior to start-up, read and fully understand the Maxim Controller section in this Manual. Turn on the controller by moving the switch to the "ON" position. Check the controller's settings by scrolling through the menu screens. The settings are factory preset at nominal values. These may need to be adjusted to meet your system's back flush needs. Be sure the Pressure Differential gauge setting is properly set once there is water flow. The recommended PD setpoint is 1-2 PSID above the "clean" gauge reading at the systems MAXIMUM flow rate. Setting this gauge at too low flow may result in continuous back flushing at higher flow rates. Note that the Pressure Differential increases with flow rate. Typical PD gauge setpoints are between 3-6 PSID, depending on flow rate.

3.3 System Start-Up (Cont.)

4 **Prime the main pump** by filling the suction line and pump volute with water. If the main pump does not have a flooded suction, then a foot valve will be required to maintain a prime after shut off. Once primed, make sure all downstream valves are open and briefly (a few seconds) switch ON the pump to begin manifold flow. It may take a few tries to remove any air from the system. Check for leaks once there is water flow. Especially around the pump, 3-way valves and manifold flange connections.

5 **Pressurize system:** If your system contains both inlet and outlet valves, first open the inlet valve slightly to allow the system to pressurize slowly. Check for any leaks around the pump, valves or flanges during this start up period. Once the system has been checked, carefully open the inlet and outlet valves the rest of the way. If your system has an external filter bypass valve, close it slowly after the Turbo Disc is running and there is water flowing in the outlet manifold.

Note - If the motor starter box has a relay in it, then the Main Pump ON-OFF switch on the front panel should be set to the **ON** position, and the Booster Pump HAND-OFF-AUTO (HOA) switch should be set to **AUTO**.

If there is NO relay in the Starter Box then the Main Pump H-O-A switch should be set to the **HAND** mode for normal operation.

See the switch labels on the motor starter box for operating instructions.

6 **Switch and leave the booster pump starter in the Automatic Mode.** The controller will turn the booster pump on and off during a back flush cycle. The back flush cycle is set at the factory for every four (4) hours but this can be set using the menu system in the electronic controller. Alternately, the Pressure Differential gauge can be set to a lower pressure momentarily to initiate a back flush cycle. Be sure to re-set the pressure indicator to 2 to 3 PSI over the “clean” filter operating pressure to ensure proper back flush filter operation.

Note - If the system has a booster pump (with a relay in the starter box), then there will be a second selector switch on the front panel of the motor starter box. The Booster Pump HAND-OFF-AUTO (HOA) switch on the front panel of the starter box should be set to the **AUTO** position for normal operation.

The OFF position will always turn the booster pump OFF, and the HAND position will always turn the booster pump ON. This switch only controls the Booster Pump motor circuit.

See the switch labels on the motor starter box for operating instructions.

Once the system is flowing water out of the outlet manifold, it is recommended that the operator manually cycle through several back flush cycles during initialization to insure proper set up and to become familiar with the system. This will also help to determine what the operational settings (periodic, pressure differential) need to be for your system.

If there is a booster pump, check and make sure it is turning on and developing pressure. If the booster pump manifold contains a pressure regulating valve, check to make sure the booster manifold pressure is between 60 and 80 psi during back flush sequence. This reading may be higher during the timing dwell period between filter pod sequences but this is normal.

3.4 Normal System Operation

The automatic Turbo-Disc filter systems are designed for indoor and outdoor use. There are limitations in cases of outdoor installations and measures must be taken to prevent damage to system components when exposed to the elements.

All Turbo-Disc pump systems have a Totally Enclosed Fan Cooled (TEFC) motor. This allows the pump to be exposed to elements including heavy rain however the pump should not be submerged in water so it is necessary that adequate drainage be provided.

All of the electronic control boxes and motor starter boxes are NEMA 4X. The NEMA 4X enclosure protects the electronic equipment against dirt, dust, hose down, corrosion, rain, snow and sleet.

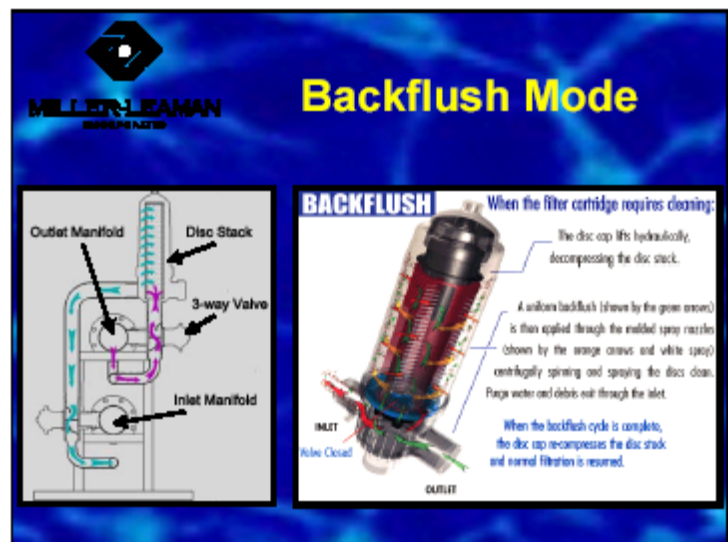
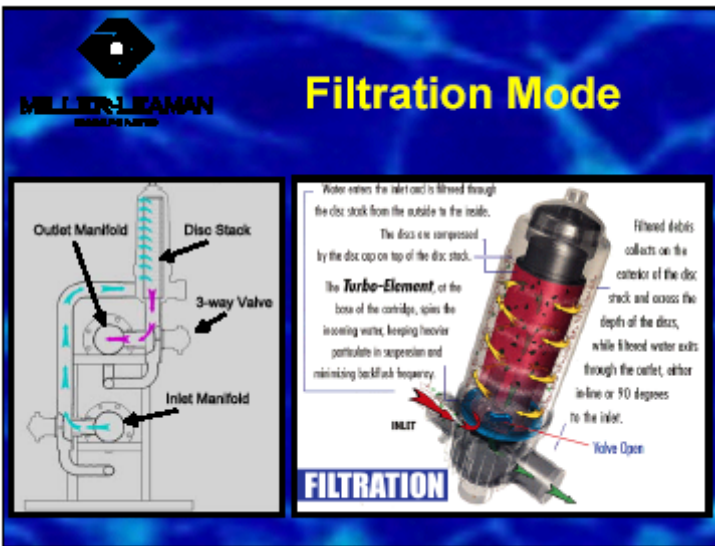

3.5 Cold Weather System Operation

This filter system is not freeze protected. If there is a risk of freezing, install the system indoors or otherwise insulate the system in a small shed with heating. Alternately, use electric heating tape or foam insulation on the piping and valves,.

If there is a potential for freezing weather, Turbo-Disc filter systems installed out doors must be winterized. The following steps are recommended for freeze protection:

1. Shut Automatic Turbo Disc system down
2. Turn off the pump at the motor starter
3. Turn off the Maxim controller
4. Shut-off the air supply
5. Disconnect power supply to the motor starter/s, the controller and the air compressor
6. Relieve system pressure (air and water)
7. Drain all water from the filter system
8. Much of the water can be drained through the inlet and outlet of the system
9. Hose bibs are located on some manifolds and can be used to drain some of the water.
10. The pump have drain plugs at the volute. Remove the plug on the bottom of the volute to completely drain the pump. Note - A small hose and valve can be used to divert the water to a desired location
11. The filter pods have chambers in the housing base that trap water. This water needs to be removed with a water vacuum. Alternately, the filter pods can be removed at the clamps and the water poured out.
12. Rinse off and drain all filters, filter housings, valves, manifolds, backwash lines and pumps to remove any residual debris.
13. Inspect and lubricate filter cartridge O-ring gaskets
 - (2) Cartridge Base O-rings (103 mm x 4 mm)
 - (1) Piston Cap O-ring (HDPE, Split. (No lubrication required))
 - (2) Internal Piston Cap O-rings (13 mm x 2 mm)
14. Replace the filter cartridges in the filter housings and secure the safety clamp
15. If the suction, discharge or backwash piping is removed cover openings to prevent foreign matter or small animals from entering the system.

If you have any questions please call 800-881-0320 to speak to a technical service representative.

Section 4 - Regular Maintenance Procedures

	INSPECT THE SYSTEM REGULARLY
	Visually inspect the <i>Turbo-Disc Filtration System</i> on a regular basis. Never attempt to operate the system with missing or damaged parts. Contact a Miller-Leaman Service Provider for replacement parts.

Turbo-Disc Filter System Maintenance Requirements

Periodic inspection and service can extend life, especially under extreme operating conditions. In such conditions it is recommended that an internal inspection be completed periodically. Routine maintenance typically consists of partial disassembly, cleaning and visual evaluation of system components.

Maintenance Requirements must be completed to satisfy the warranty requirements. Along with the **Maintenance Schedule** there is a **Maintenance Check-List**. Simply put in the date and record the completed task. This table should be kept up to date at all times to keep the filter equipment in top shape and to satisfy the requirements of the warranty.

The following maintenance forms are provided in the Appendix. Copy them and keep them up to date as an aid in troubleshooting if you have problems later.

Maintenance Log - This information should to be filled out as the maintenance is done. These forms can be very helpful when troubleshooting the filter system.

Again, all paperwork should be filled out to ensure that all the warranty requirements are met.

Do not use the originals. Make extra photocopies of the Check-List and Maintenance Log, provided in the appendix of this manual.

4.1 Maintenance Schedule

A regular scheduled system maintenance program is important in keeping your system at its best performance.

Routine Inspection

- Ensure that the controller is properly working, and that all backflush settings are properly adjusted.
- Check the system pressures (inlet and outlet) and that the PD gauge matches the inlet/outlet differential. Make sure the pressure differential gauge is set at the correct PD setting and that it properly initiates a backflush.
- Look for any leaks in the system and drain the inlet filter of any dirt/water that may be inline.

Monthly Inspection / Maintenance

- Manually initiate a back flush cycle and make sure all valves are actuating and the filters are back flushing properly.
- Open one or all pods and check for any visible damage and ensure that all discs are being sufficiently cleaned. If the discs are not clean and in good condition they need to be cleaned or refurbished.
- Inspect the solenoid manifold, making sure there are no air leaks and that the manual overrides are NOT turned on.

Seasonal / Annual Maintenance

- Inspect the system for any leaks. This should include all victaulic couplings. The victualic gaskets should be lubricated with silicon gasket grease to prevent them from drying and cracking.
- Remove all Turbo-Disc Filter Cartridges. Remove the filter cap. Inspect the upper o-ring as shown in Figure 5.1. (Page 44) If the o-ring shows any signs of wear or cracking, replace it. If this o-ring does not seal, the filters will NOT backflush.

We recommend replacing these o-rings every 2 years.

- Remove the disks for cleaning. Keep each disc stack separately to make sure the disc count does not change.
- Check all of the 3-way valves to make sure they are operating properly. Remove the top valve cover and inspect a few of the valves for signs of wear on the upper diaphragm and lower seat. Depending on the back flush frequency and water conditions, these 3-way flow control valves may need to be rebuilt.

We recommend disassembling and inspecting the flow valves after every 2 years of operation.

4.2 Maintenance Check-List

The chart below should be used as a general guide for every day inspections and seasonal maintenance. In the Appendix of this manual is a specific Turbo Disk Maintenance Schedule for Summer-Fall and Winter-Spring.

DAILY INSPECTIONS
1. General visual inspection of the Filter.
2. Check for leakage around the clamps of the filter pods.
3. Check of the Operating Conditions (pressure, temperature, flow rate, pH).
4. Check for variations or increases in the Filter head loss (P1 minus P2).
PERIODIC MAINTENANCE
1. Disassemble the pod cover and inspect the housing base O-ring. Lubricate with silicone grease as needed.
2. Disassemble all of the pods and inspect the Piston and O-rings. Lubricate with silicone grease as needed.
3. Check the filter disc stack for clean-up. If they are dirty, wash and inspect the filter discs for wear or damage. Replace as needed.
4. Check of all the pipe joints and seals for leakage or signs of leakage.
5. Manually activate a backwash to verify that the backwash sequences through all of the stations correctly
6. Perform inspections on the Victaulic couplings and do maintenance as required.

Note 1: The P1 and P2 designations are the pressures at the inlet and outlet manifolds respectively. Their difference is the Equipment head loss.

Note 2: The maintenance period should be determined by the user according to the amount of usage and degree of filtering at their installation.

Page intentionally left blank

5 Maintenance of Filter Cartridge Assembly - Inspection and Cleaning

In this section are described some very useful actions for the preparation of the *Equipment Maintenance Plan*. The checking period depends on the operation conditions, characteristics of the water to be filtered, operation hours, number of backwash cycles, and pressure differential recuperation after backwash.

Miller-Leaman, Inc. recommends a three month period between the inspection of the components which involve the disassembly of the filtering element. This maintenance period should be determined by the user according to the unique characteristics of their installation.

5.1 Exploded View of the Filter housing and filter



- 1— COMPLETE FILTER
- 2— LID P/N H-2301
- 3— COMPLETE CARTRIDGE P/N ATD-CART-XXX
- 4— CLAMP ASSY P/N H-1101
- 5— FILTER BODY GASKET P/N H-1501E (EPDM)
- 6— FILTER BODY
- 7— PRESSURE GAUGE
- 8— PORT CAP GASKET
- 9— THREADED CAP
- 10— PISTON CAP ASSEMBLY (SEE # 19 TO # 24)
- 11— DISC STACK P/N ATD-DISC-XXX
- 12— PISTON CAP O-RING P/N ATD-5505 *
- 13— CARTRIDGE FRAME W/ HELIX PLATE
- 14— CHECK VALVE W/ GASKET
- 15— CHECK VALVE SPRING
- 16— C-V SPRING RETAINER
- 17— PORTED BASE NUTS (4)
- 18— BASE O-RINGS (2) P/N H-5106E *
- 19— PISTON CAP "A" PIECE
- 20— SS P-C WASHER (2)
- 21— PISTON CAP SPRING
- 22— PISTON SHAFT O-RING P/N ATD-5503 *
- 23— PISTON CASE "B" PIECE
- 24— PISTON CAP RETAINER CLIP P/N ATD-5518
- * 5-PIECE O-RING KIT P/N ATD-5528
- 24 to 29— CLAMP COMPONENTS

INDIVIDUAL COMPONENTS ALSO AVAILABLE

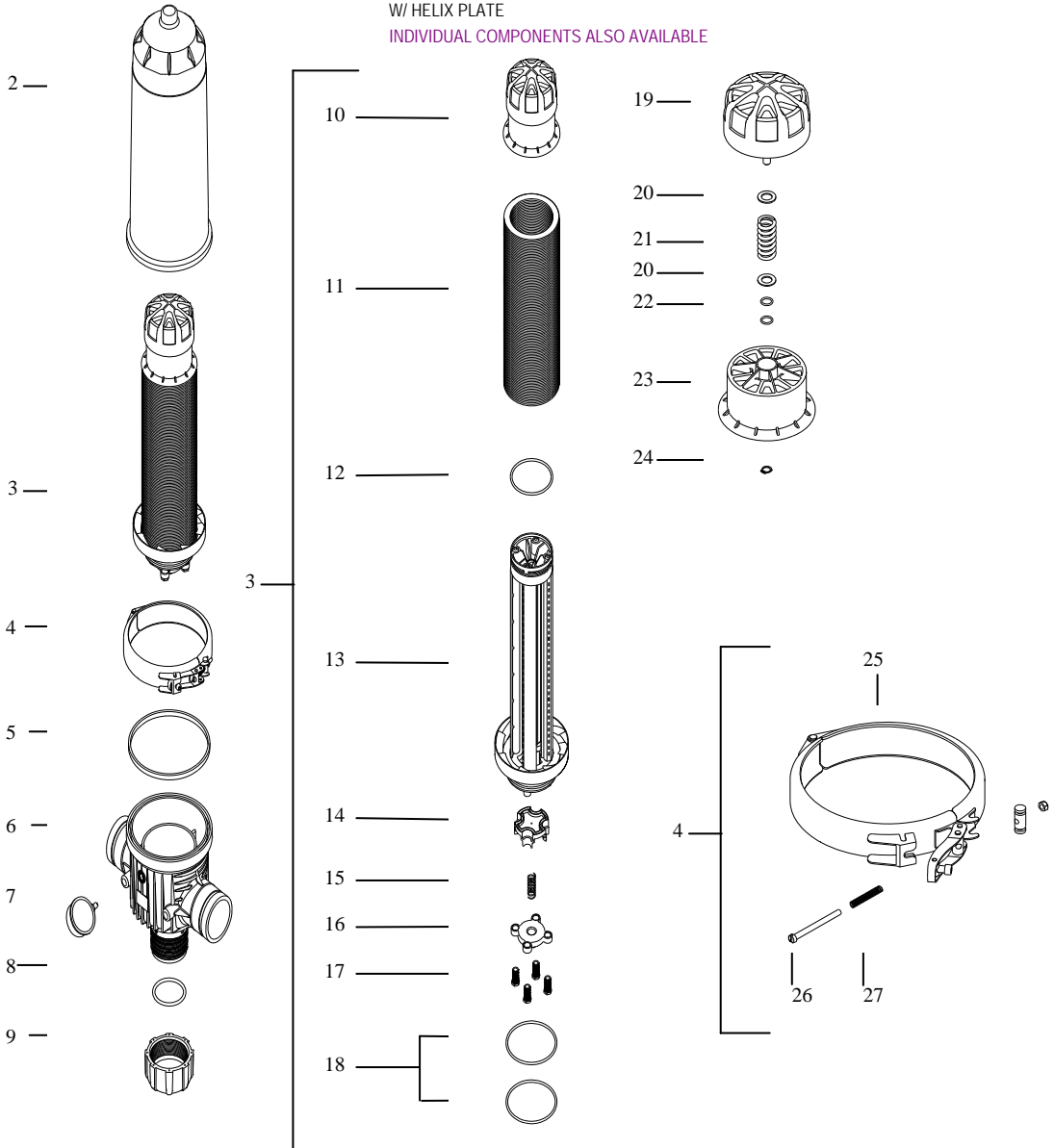



5.2 Parts list of the Filter housing and filter

ITEM	PART NUMBER	DESCRIPTION of PART	QTY
1	ATD-2SV-XXX	2" Automatic Turbo-Disc Filter, specify micron, 2" VIC -90 degree connection	1
	ATD-2SW-XXX	2" Automatic Turbo-Disc Filter, specify micron, 2" VIC -Inline connection	
	ATD-3NV-XXX	3" Automatic Turbo-Disc Filter, specify micron, 3" VIC -90 degree connection	
	ATD-3NW-XXX	3" Automatic Turbo-Disc Filter, specify micron, 3" VIC -Inline connection	
2	H-2301	Lid	1
3	ATD-CART-XXX	Filtration Cartridge, specify the micron size	1
4	H-1100	Clamp	1
5	H1501E	Filter Body Gasket	1
6	H-1202	Filter Body Gasket -2" VIC connections, 90 deg	1
	H-1203	Filter Body Gasket -2" VIC connections, Inline	
	H-1302	Filter Body Gasket -3" VIC connections, 90 deg	
	H-1303	Filter Body Gasket -3" VIC connections, Inline	
7	PG-1/4-150	Pressure Gauge (Gauge is not included and the Port is normally plugged)	
8	See #9	Threaded Cap O-Ring	1
9	H-3102	Threaded Cap, 2"	1
	H-3203	Threaded Cap, 3"	
10	ATD-5525	Piston Cap Assembly	1
11	ATD-DISC-XXX	Filtration Disc Stack, specify the micron size	1
12	ATD-5505	Piston Cap O-Ring (HDPE, Split O-Ring)	1
13	ATD-5530	Cartridge Frame with Helix Element	1
14	ATD-5513	Check Valve	1
15	ATD-5515	Check Valve Spring	1
16	ATD-5516	Check Valve Spring Retainer	1
17	ATD-5519	Spray Bar Nut, ported	4
18	H-5106E	Cartridge Base O-Ring (103 mm X 4 mm)	2
19	ATD-5501	Cartridge Cap	1
20	ATD-5517	Cartridge Cap Washer	2
21	ATD-5502	Cartridge Cap Spring	1
22	ATD-5503	Internal Cartridge Cap O-Ring (13 mm X 2 mm)	2
23	ATD-5504	Cartridge Cap Piston Case	1
24	ATD-5518	Cartridge Cap Retainer Clip	1

5.3 Maintenance and cleaning of the filter housing pod and Turbo Disc filter element stack

Each filter pod has a Retaining Ring with Safety Clamp attached to prevent the accidental opening of the filter. Follow these instructions for safely opening and closing the filter pod assembly.

	WARNING - PRESSURE EQUIPMENT
	Make sure the filter unit is <u>depressurized</u> before opening the clamp ring. Close the inlet and outlet valves to isolate the filter.

Opening instructions

- 1 Unscrew the safety lock nut.
- 2 Turn the anti-opening retaining clip.
- 3 Open the retaining ring using the built-in handle.
- 4 Carefully remove the filter lid.

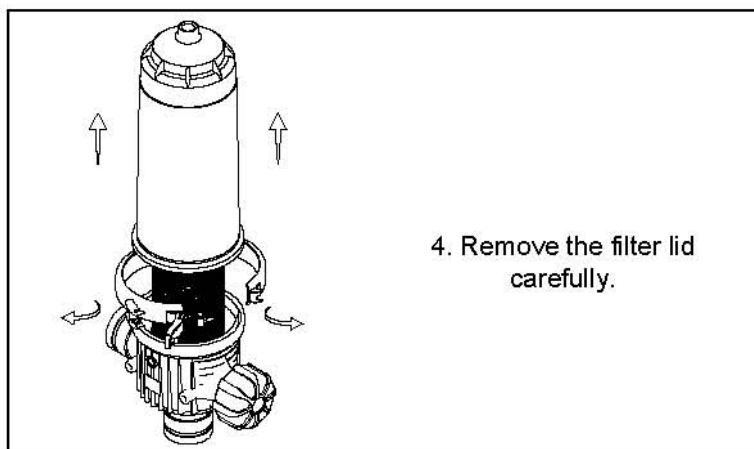
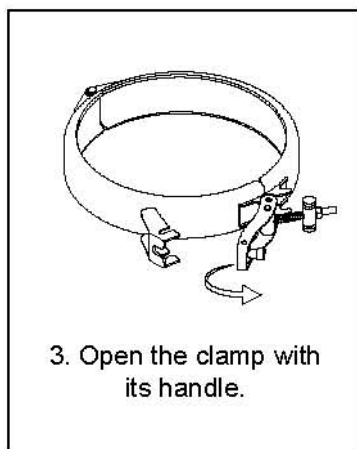
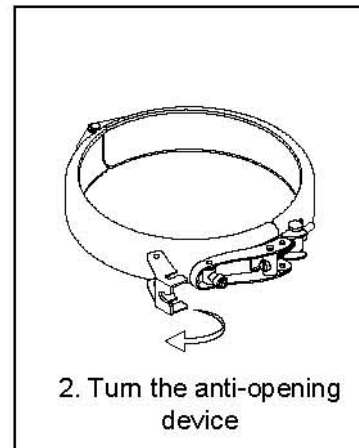
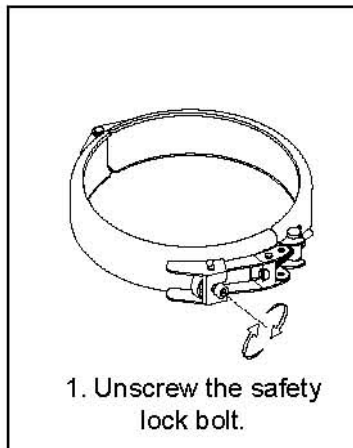
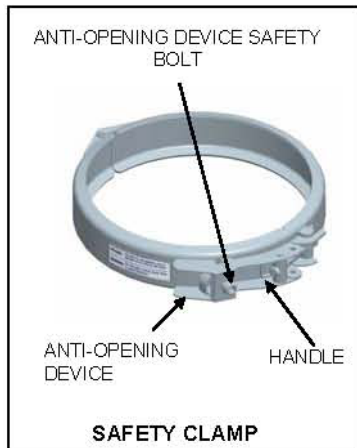

Follow these instructions for cleaning the individual filtering discs in the filter element.

- 1 Open the safety clamp and carefully remove the pod lid. See section 6.2 Filter opening and closing, for procedure details.
- 2 Carefully remove the filter element
- 3 Turn the piston until it is loose.
- 4 Lift and remove the piston
- 5 Take the filter discs off of the filter stack. Do not mixed the filter discs with other filter elements (colors). Likewise do not add or subtract the number of filter discs in the filter stack.

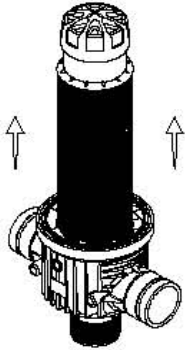
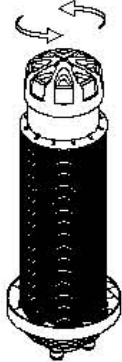
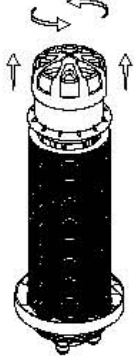
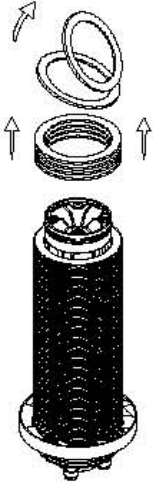
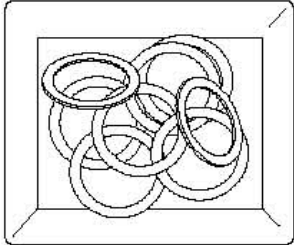
 <p>2. Extract the filtering element carefully.</p>	 <p>3. Turn the piston until it loosens.</p>	 <p>4. Remove the piston.</p>
 <p>5. Extract the discs. Do not mix discs from different filters to avoid changes in the number of discs per filtering element.</p>	 <p>A weak solution of Water and Ammonia, Sulfuric acid, or Hydrochloric acid can be used to clean these filter discs, <u>except</u> if they are made out of polyamide plastic</p> <p>6. Clean the discs using clean water or an acid solution if you cannot remove the dirt from the discs. In this case you should follow the protection measures according to the <i>Safety Sheet</i> regarding the acid to use. For discs made of polyamide do not use an acid solution. You can clean this discs using a diluted solution of sodium hydroxide (<10%). Check the manufacturing material of the discs in section 2.4 "Components and spare parts"</p>	

- 6 Clean and wash the filter discs using only clean water. Alternately a weak acid solution can be used to clean the filter discs – **except** for polyamide filter discs.

Caution - Be sure to follow and use all the safety protection equipment (clothing, gloves and safety glasses) and follow all the Material Safety Data Sheet MSDS procedures for any given acid.

Note 1 - Use only clean water to wash other parts of the filter. Do not clean or wash any other parts of the filter in any acid solution.

Note 2 - Polyamide disks can be cleaned and washed in only a weak solution (less than 10%) of sodium hydroxide.

Note 3 - You can check the material used in the filter discs in Section 2.4 – Components and Spare Parts.

- 7 Place the discs in the filter element stack. For the correct operation of the filter do not mix of different mesh sizes (colors) or add or subtract the number of discs on the stack.

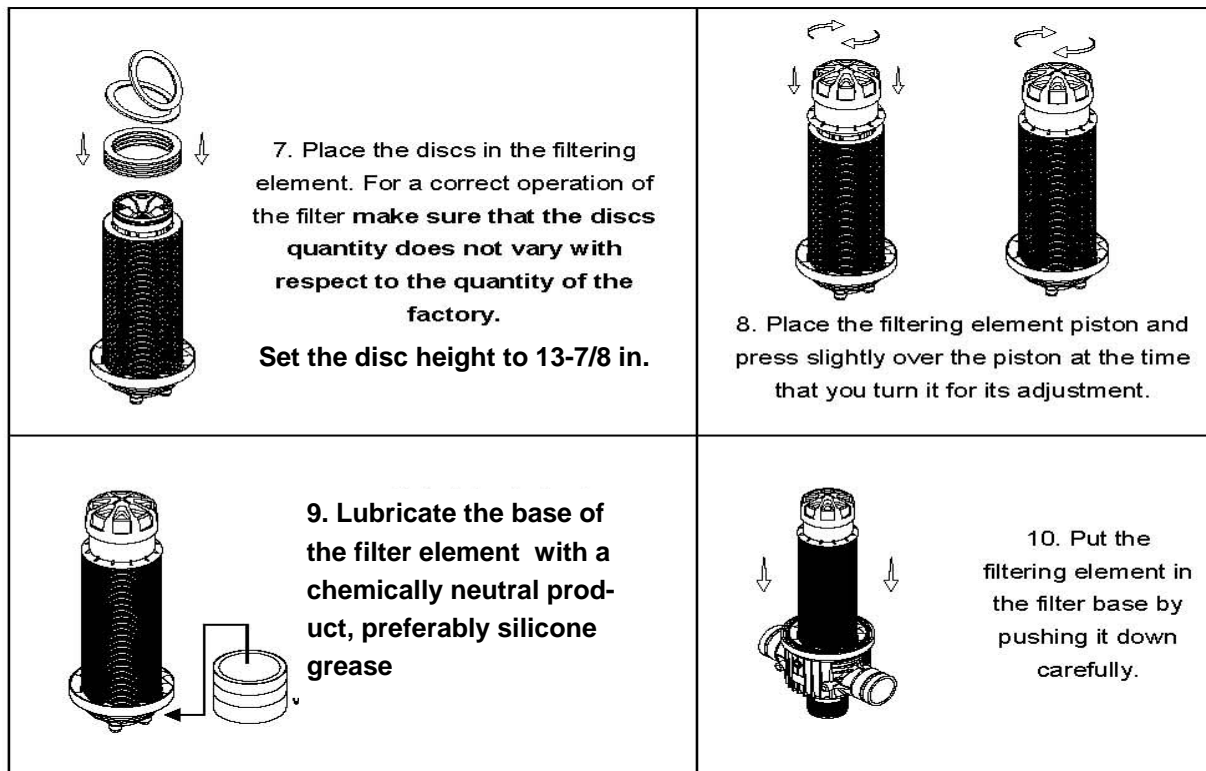

- 8 Place the filter element piston over the disc stack. Press the piston down and then turn clockwise to lock it into position.
- 9 Lubricate the two (2) lower sealing O rings of the filter stack with Silicone grease or other similar lubricating grease. Check the chemical compatibility of the grease with the housing base plastic molding.

- 10 Carefully put the filter stack on to the housing base and press it down firmly.
- 11 Place the pod lid on the filter stack and put the closing ring around the filter joint. Secure the ring with the safety screw and clip. See section 6.2 – Filter Opening and Closing

	WARNING
	Incorrect alignment of the filter element in the housing base could cause the unit to not filter the supply water.

	WARNING
	Be sure to install the Safety lock bolt to avoid the accidental opening of the filter unit during maintenance operations.

	WARNING
	Always use adequate Personal Protection Equipment (PPE) before working on hazardous equipment. All personal should have approved: Clothing, gloves, and safety glasses.

Closing instructions

- 1 Inspect the inside of the housing base for any foreign objects or debris in the unit. Clean or flush out the debris as necessary.
- 2 Inspect the sealing lip around the safety clamp for scale or defects in the sealing gasket.
- 3 Carefully place the filter pod lid over the housing base and align the safety clamp in place.
- 4 Close the safety clamp handle along with installing the anti-opening clip
- 5 Install and tighten (do not force) the safety lock bolt in place to avoid accidental opening of the filter unit.

	WARNING
	Be sure to install the Safety lock bolt to avoid accidental opening of the filter unit during maintenance operations.

5.4 Maintenance of Filter Cartridge - O-Ring Inspection and Replacement

	WARNING - PRESSURE EQUIPMENT
	<p>Make sure the filter unit is depressurized before opening the clamp ring. Close the inlet and outlet valves to isolate the filter.</p>

The following steps are used for inspecting and replacing the filter stack O-rings

- 1 Open the safety clamp and carefully remove the filter lid. See section 6.2 – Filter Opening and Closing.
- 2 Carefully remove the filter element stack. See section 7.2.2 – Disc Cleaning, paragraph
- 3 Remove the piston actuator. See section 6.2 paragraph 3 and 4 – Disc Cleaning
- 4 Check the condition of the O-Rings on both the top and bottom of the filter stack.
- 5 Replace the O-Rings if they are worn or have flattened sides on them.
- 6 Replace the actuating piston back on the filter stack, turning it so that it is aligned. See section 7.2.2 – Disc Cleaning.
- 7 Inspect the HDPE Piston O-Ring for damage.
- 8 Lubricate the housing base of the filter stack at the two (2) 103 mm X 4 mm Cartridge Base O-Rings and groove. Carefully push the disc stack in the housing base. See section 7.2.2 paragraph 9 & 10 Disc Cleaning.
- 9 Put the pod lid on the filter stack and secure with the safety clamp. See section 6.2 – Filter Opening and Closing.

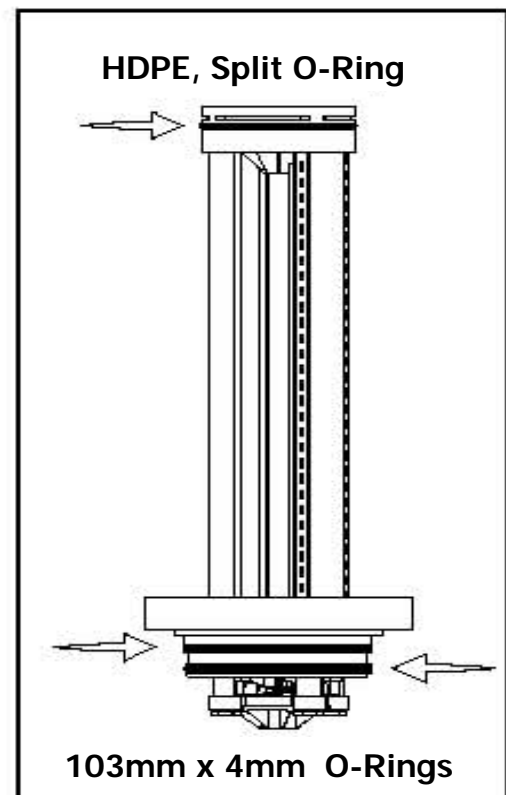

Follow the instructions below for inspecting the piston and spring mechanisms.

- 1 Open the safety clamp and carefully remove the pod lid. See Section 5.5
- 2 Remove the filter element. See section 6.2 – Filter Opening and Closing.
- 3 Remove the actuator spring and retainer cup. Special tool used to remove cup then disassemble the piston and cup assembly.
- 4 Clean these parts in clean water.
- 5 Reassemble the actuator spring and retaining cup.

- 6 On the housing base, start with any two (2) opposite metric M14x1 screws and tighten snugly.
- 7 Put the two (2) remaining screws on and then tighten all of the screws with the 17mm spanner wrench.
- 8 Unscrew the metric M14x1 screws in the filter element base with a metric 17mm spanner wrench. Always unscrew two (2) opposing screws first.
- 9 After the first two (2) screws are removed and set aside, unscrew the second two (2) screws. Hold the retaining bracket in place – for the next step.

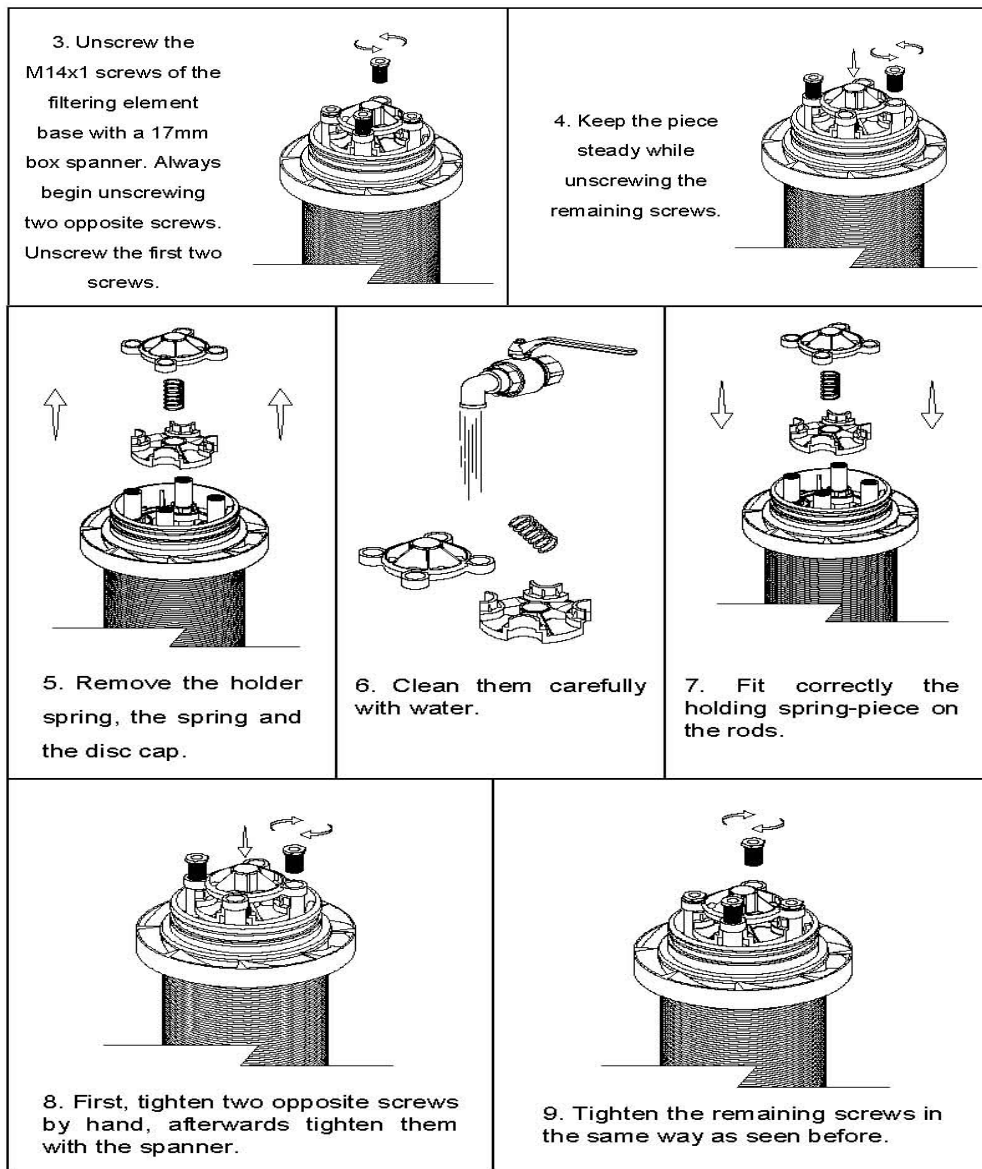

5.5 Filter Piston actuator maintenance.

- 1 Open the safety clamp and carefully open the pod lid.
- 2 Remove the filter element. See section 7.2.2 paragraph 2 – Disc Cleaning
- 3 Remove the actuator piston See section 7.2.2 paragraph 3 and 4 – Disc cleaning
- 4 Disassemble the actuator piston parts and inspect for wear and damage. Replace as necessary. See section 2.4 – Components and spare parts.

Follow the steps below for actuator piston removal and cleaning.

- Step 1 Remove the snap ring (p/n Metric 10-25mm, DIN 5254) with C-ring pliers (p/n xxxx) and save the C-ring off to the side. Replace the c-ring if it is deformed.
- Step 2 Remove the inner piston cup from the outer piston Shell.
- Step 3 Check the 13mm x 2mm O-Ring(s) in the inner piston cup. Clean and replace as necessary.
- Step 4 Remove the washers and piston spring from the outer piston shell. Clean and replace as necessary.

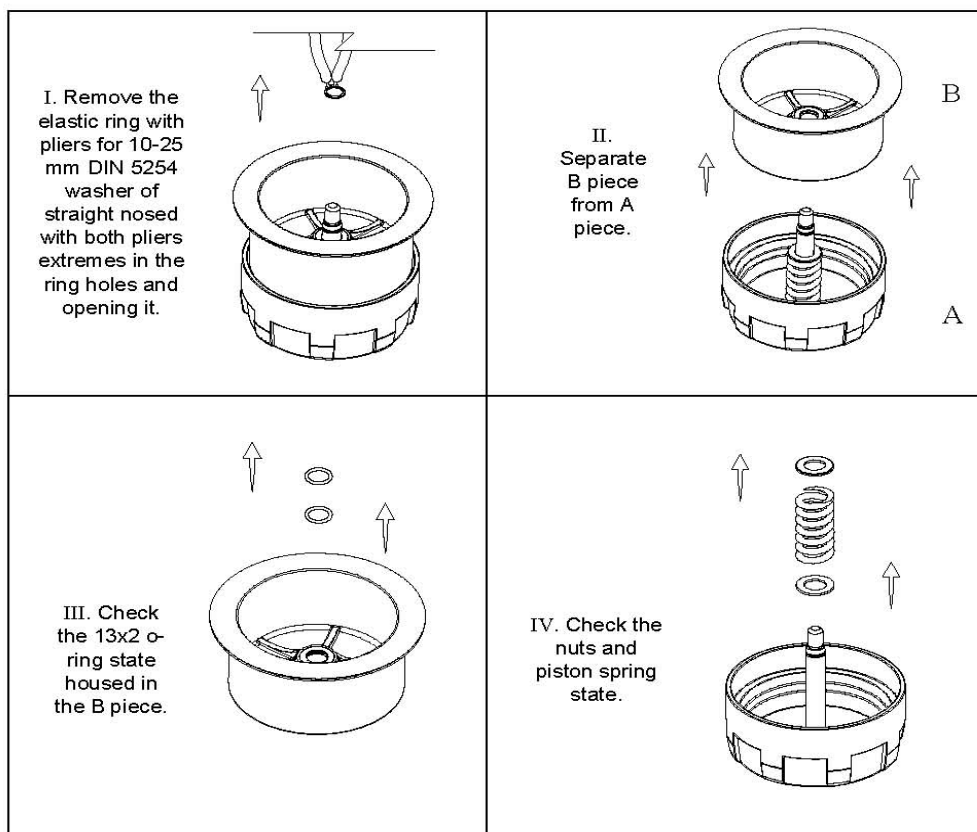

Follow the steps below for actuator piston components assembly

- Step 1 Apply Silicone grease to the threaded rod in the outer piston shell
- Step 2 Place the 14.5x25x15 washer and the 64x24x4 piston spring (ESP metric type) and the second 14.5x25x15 nut on the threaded rod.
- Step 3 Place the two 13 x 2 O-rings into the inner piston cup. Use Silicone grease on these parts.
- Step 4 Insert the inner piston cup into the outer shell. Be sure the O-Rings stay in place during assembly.

Step 5 Insert the C-ring into the groove in the inner piston shaft using the C-ring pliers.

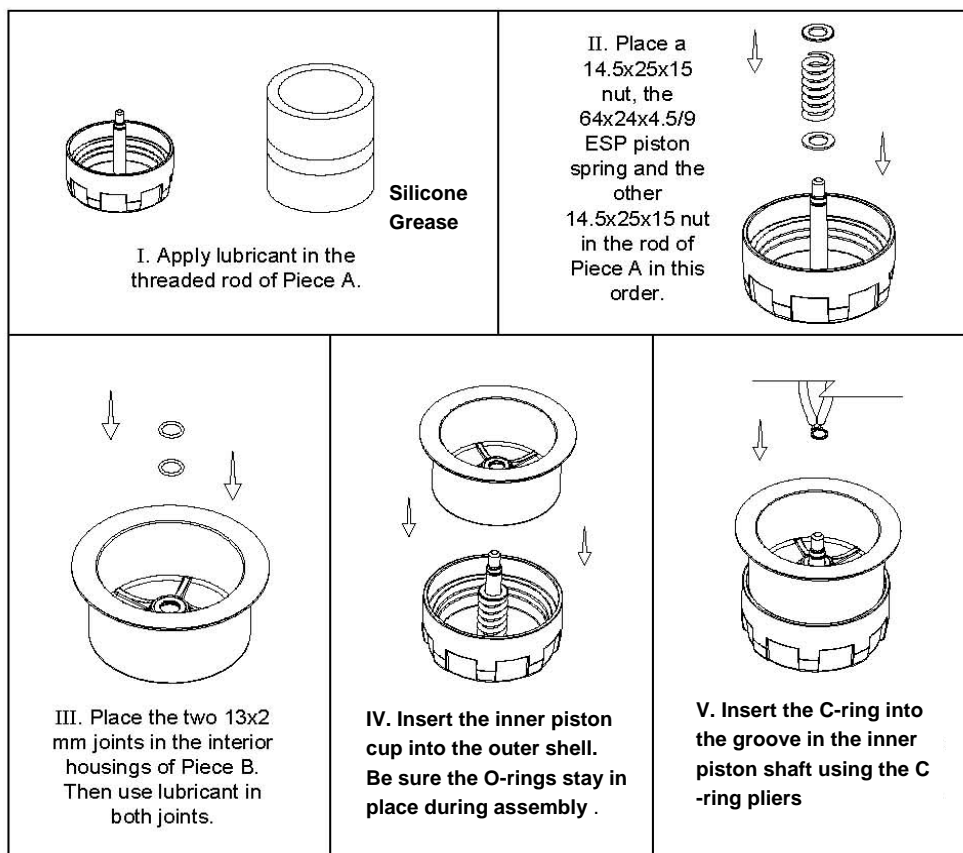

5.6 Solenoids and Air Valves - Inspection and Maintenance

The Turbo Disc system may be built with different solenoids and / or air valves. However most of the current systems use Burkert manifold type solenoid air valves.

Manufacturer: Burkert Contromatic USA, 2602 McGaw Ave, Irvine, CA 92614 - www.burkert-usa.com - Phone 940.223.3100

General Description: The Burkert type 5470 solenoid air valves include high cycle life diaphragm seat design valves in 3/2 and 4/2 way versions. The valves consists of three modules: valve body with servo-diaphragm plungers and valve seal, solenoid operator and sub-base assembly.

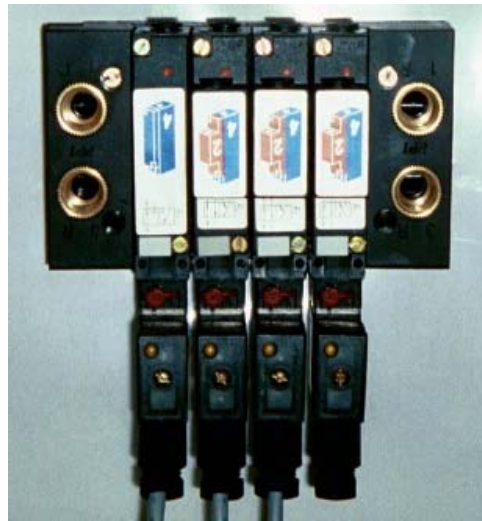

The body and air valve internal parts are made of high quality thermoplastic and a stainless steel return spring. A 16mm rocker solenoid valve type 6106 with rectifier is used as the pilot. Spade connectors are used for electrical contact, per DIN 43-650 Form C. Spades are compatible with type 2506 cable plugs or female receptacles or Berkert valve manifolds. Coils can be rotated to position the spades in front for cable plugs or out the back for modular connection.

The manifolds can be powered through various field-bus systems, multi-pole or common terminals. The block assembly is made with pneumatic modules using integrated locking technology. Type 6106 impulse version is a bi-stable valve used as pilot valve for Type 5470. The operation has to be done through external pole reversal (e.g. PLC)

The advantages of the impulse version are functional safety during short time power failure, saving of energy and low heat generation. It is applicable for switching systems with impulse control.

Troubleshooting and Maintenance: The solenoid air valves are fully tested before they leave the factory and should need little or minimal maintenance. Ensure that the air lines are fully seated into the manifold block and that the air line numbers and valve numbers match up. Each solenoid valve has a red manual actuator lever (normally horizontal) that can be used to actuate the solenoid valve for troubleshooting only (energize by switching it downward and then returning the lever to the horizontal position) .

The electric solenoid coil over time may become weak or inoperative. If a spare solenoid actuator coil is available, it can be swapped out to see if the problem is resolved. Also verify that the solenoid plug lights up when the air solenoid valve is being actuated by the microprocessor controller and that there is air pressure and air flow to the corresponding down line process valve.

5.7 Air Override Check Valves - Inspection and Maintenance

Troubleshooting and Maintenance: Normally the check valves will need no maintenance. However if water is found leaking from the solenoid air valve manifold unit then there could be several causes for this leakage. One is a torn or damaged backflush water flow valve diaphragm. The other is a failure of one of the air override check valves located on the top of the filter covers. To check for a faulty check valve, remove the 1/4" black air line from the air override check valve assembly at the top of the filter pod and determine if water is passing from the filter up through the check valve. Also verify that the indicator arrow on the side of the check valve is pointing downward into the filter.



5.8 Sustaining Valves - Inspection and Maintenance

The Turbo Disc filter requires 60 PSI downstream pressure to properly backflush. If the downstream pressure is less than 60 PSI, a pressure sustaining valve should be installed directly downstream of the filter outlet manifold, or alternately a booster pump could also be installed off the outlet manifold. A pressure sustaining valve is also recommended for applications where there are high PPM concentrations and also where there is an irrigation area at a lower level elevation than the filter system site.



The sustaining valve should be set to activate prior to and for the duration of the backflush cycle and should be deactivated when not in the backflush cycle.

During the backflush mode, a check of the system pressure and the differential pressure are a good indication the sustaining valve is working correctly.

Troubleshooting and Maintenance: The water flow control valves are fully tested before they leave the factory but do need periodic maintenance over time. Do a visual inspection first to en-

sure that the air lines are fully seated into the manifold block and that the air line numbers and valve numbers match up. Each solenoid valve has a red manual actuator lever (normally horizontal that can be used to manually actuate the flow control valve for troubleshooting only (energize by switching it downward and then returning the lever to the horizontal position) .

Use the troubleshooting chart below for the Bermad 400 valve. Other flow control valves may have been used in your sistem, but the basic troubleshooting routine remains the same.

Symptom: Inoperative Bermad 400 Series Flow Control Valve	
Possible Causes:	Solutions:
Clogged pilot valve prevents water from reaching the diaphragm for actuation. Not all units are equipped with a pilot	Disassemble the pilot valve and remove any debris buildup. See attached instructions for cleaning the pilot valves.
Torn diaphragm inside flow valve.	Remove valve cover by removing the (4) corner bolts. If diaphragm is torn contact manufacturer for replacement part.
Air Solenoid not energizing.	Verify that solenoid is getting power. If not, See the previous Section on Inoperative Controller.

5.9 Main Process Pump - Inspection and Maintenance

The Turbo Disc system has been thoroughly tested at the factory. However at start up for the first time, verify the following:

- Clockwise shaft rotation
- No excessive vibration or noise
- No overheating of the motor
- No or low water output

Troubleshooting and General Maintenance.

Lubrication: The Liquid End of the pump requires NO lubrication. Wear rings. Packing rings and models using a mechanical shaft seal, are lubricated by the liquid being pumped. Do not run dry. NOTE: Grease fitting in the packing area is for priming only - see PRIMING in the start-up section for instruction. The motor bearings are lubricated at the factory. Re-lubrication at intervals consistent with the amount of use will provide maximum bearing life. Refer to the Motor Instruction Manual for proper motor lubrication and maintenance instructions.

Performance Check: Periodically check the output of the pump. If performance is noticeably reduced, refer the Troubleshooting Chart.

Observational Check: When the pump and system operation have been stabilized, verify the pump unit is operating properly by observing the following conditions:

- Vibration. All rotating machines can be expected to produce some vibration. However excessive vibration can reduce the life of the unit. If the vibration seem excessive discontinue operation, determine the cause of the vibration, and correct it.
- Noise. When the unit is operating under load, listen closely for unusual sounds that might indicate that the unit is in distress. Determine the cause and correct the problem.
- Operating temperature. During operation, heat is dissipated from the pump and driver. After a short period of time, the surface of the pump bracket will be quite warm (as high as 150°F), which is normal. If the surface of the pump bracket or driver is excessive, discontinue operation, determine the cause of the excessive temperature rise, and correct. Bearing will run hotter fro a brief run-in period after which is normal. However, worm bearings will cause excessive temperatures and need to be replaced. The pump is cooled by water flowing through it, and will normally be at the temperature of the water being pumped.
- Stuffing Box. After a short period of operation verify that the stuffing box area and gland are not hot. If heating is detected, loosen the gland nuts evenly until water is just running out of the stuffing box in “droplet” form. Water must not be streaming or spraying out. Verify cool operation periodically. Adjust gland nuts evenly as necessary for lubrication and cooling of the packing. If packing is tightened to the limit of the packing gland travel, additional packing is necessary.

Packing. *Starting a new or replacement pump.* Before starting a pump for the first time, loosen the gland nuts and retighten to finger tight. Proceed with pump start-up procedure. Allow the packing to leak liberally for a few moments. Then tighten the gland nuts one complete turn each until the leakage is reduced to 40 to 60 drops per minute.

Mechanical Seal. Adjustment or maintenance is normally not required. The seal is enclosed within the pump and is self adjusting. Seal is cooled and lubricated by the liquid being pumped. Do not run the pump dry!

Pump Protection - Cold weather /wet weather installations.

- System Drains - Provide drain valves to empty the system, including the pump case, to prevent freezing damage.
- Shelter - If possible, provide shelter for the unit to protect it from the weather. Allow adequate space around the pump unit for service. When effectively sheltered, a small amount of heat will keep the temperature above freezing. Provide adequate ventilation for the unit when running. For severe weather problems, or where other shelter is not practical, a totally enclosed fan cooled (TEFC) type motor should be considered.
- Condensation - When the temperature of the metal parts of a motor are below the dew point and the surrounding air is moist, water will condense on the metal surfaces which over time will cause corrosion damage. In severe conditions, a space heater should be considered to warm the motor unit.

Note: The following information is from the Berkeley Motor Driven Pump User Manual (.pdf file) and is for basic troubleshooting only. Complete information on this and other motor pump products can be found online.

5.10 Main Process Pump / Booster Pump Troubleshooting Chart

SYMPTOM	PROBABLE CAUSE																	
	GROUP I ELECTRICAL									GROUP II MECHANICAL					GROUP III SYSTEM			
	A	B	C	D	E	F	G	H	I	A	B	C	D	E	F	A	B	C
Pump runs, but no water delivered										X		X				X	X	
Not enough water delivered			X	X					X	X	X		X			X	X	
Not enough pressure			X	X					X	X	X		X			X	X	
Excessive vibration									X	X	X			X			X	X
Abnormal noise										X	X	X		X	X		X	X
Pump stops	X	X	X	X	X	X	X	X										
Overheating		X	X	X					X		X		X	X	X			X

CAUSE	CORRECTIVE ACTION
I. ELECTRICAL	
A. No voltage in power system	Check phase-to-phase on line side of starter contactor. Check circuit breaker or fuses.
B. No voltage on one phase (Three Phase Units)	Check phase voltage on line side of starter contactor. Isolate open circuit (circuit breaker, fuse, broken connections, etc.)
C. Low voltage at motor	Running voltage across each leg of motor must be $\pm 10\%$ of nominal voltage shown on nameplate.
D. Motor leads improperly grouped for voltage	Refer to lead grouping diagram on motor nameplate.
E. Control failure	Check control device, starter contactor, H-O-A selector switch, etc., for malfunction.
F. Thermal overload switch open	Check phase-to-phase on line side of starter contactor.
G. Installation failure	Check motor or windings to ground with megohmmeter.
H. Open windings	Check leg-to-leg with ohmmeter.
I. Frequency variation	Check frequency of power system. Must be less than 5% variation from motor nameplate rating.
II. MECHANICAL	
A. Flow through pump completely or partially obstructed	Locate and remove obstruction. Refer to Repair Instructions for disassembly.
B. Wrong direction of rotation	Reverse rotation of three phase motor by interchanging any two leads. See manufacturer's Instructions for reversing single phase motor.
C. Pump not primed	Reprime. Inspect suction system for air leaks.
D. Internal leakage	Check impeller for wear of controlled clearances (See Repair Instructions).
E. Loose parts	Inspect. Repair.
F. Stuffing box not properly adjusted	Adjust gland.
III. SYSTEM	
A. Pressure required by system at design flow rate exceeds pressure rating of pump	Compare pump pressure and flow rate against pump characteristic curve. Check for closed or partially closed valve in discharge piping system. Reduce system pressure requirement. Increase pressure capability of pump.
B. Obstruction in suction piping	Locate and remove obstruction.
C. Pressure rating of pump exceeds pressure requirement of system at design flow rate	Compare pump pressure and flow rate against pump characteristic curve. Inspect discharge piping system for breaks, leaks, open by-pass valves, etc. If necessary, reduce flow rate by partially closing discharge valve.

5.11 Checking the Direction of Rotation of the Main and Booster Pump Motors

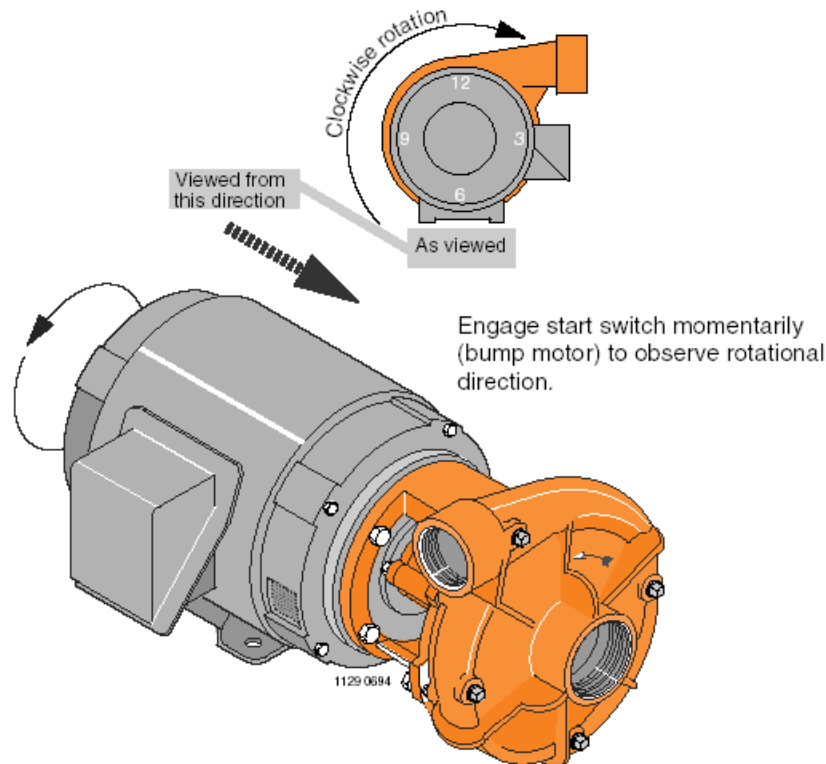

The direction of pump rotation is determined by viewing the liquid end of the pump from the back or shaft side and **not** from looking into the impeller eye or front volute case. A rotation arrow is cast into the pump body and shows the correct rotation. If a centrifugal pump is running backward it will still pump liquids. However the GPM and head discharge pressure will only be a fraction of the published performance ratings.

Electric motors:

Single phase: Refer to the wiring information on the motor plate to obtain proper rotation

Three phase: If the pump runs backwards, reverse any two leads coming off the incoming power mains at the starter box (L1, L2 and L3) until the proper rotation is obtained. You can reverse L1 & L2, L2 & L3, or L1 & L3.

CAUTION: Be sure to completely disconnect all power from the electrical control panel before making any changes. If you are not sure how to safely do this, have a qualified electrician do the electrical work.

5.12 Booster Pump - Inspection and Maintenance

The booster systems are equipped with a booster pump that draws filtered water from the outlet manifold and directs it through the booster manifolds to backwash the filters. The advantage of this type of system is to produce adequate pressure for the backwash cycle with a relatively small pump that only operates for short periods of time. The booster pump is sized according to the conditions of the main system, primarily the flow and pressure that are supplied to the filter system.

Booster Pump operation during the Backwash Mode is initiated by pressure differential, timer or manually by the controller. When the controller is energized to start a backwash cycle all the filters consecutively backwash either one or two filters at a time. The booster pump is actuated by a relay that is wired to the master switch in the controller so it will automatically run when the controller initiates a backwash cycle.

The same basic procedures are followed as outlined previously in the section on main process pump maintenance and troubleshooting. Study and review the Main Process Pump section on pages 59 thru 61

Maintenance and troubleshooting. The Turbo Disc system has been thoroughly tested at the factory. However at start up for the first time verify the following:

- Clockwise shaft rotation,
- No excessive vibration or noise,
- No overheating of the motor,
- No or low water output

Lubrication: The Liquid End of the pump requires NO lubrication. Wear rings. Packing rings and models using a mechanical shaft seal, are lubricated by the liquid being pumped. Do not run dry.

Observational Check: When the pump and system operation have been stabilized, verify the pump unit is operating properly by observing the following conditions:

- Vibration. All rotating machines can be expected to produce some vibration. However excessive vibration can reduce the life of the unit. If the vibration seem excessive discontinue operation, determine the cause of the vibration, and correct it.
- Noise. When the unit is operating under load, listen closely for unusual sounds that might indicate that the unit is in distress. Determine the cause and correct the problem.
- Operating temperature. During operation, heat is dissipated from the pump and driver. After a short period of time, the surface of the pump bracket will be quite warm (as high as 150°F), which is normal. If the surface of the pump bracket or driver is excessive, dis-

continue operation, determine the cause of the excessive temperature rise, and correct.

Bearing will run hotter from a brief run-in period after which is normal. However, worn bearings will cause excessive temperatures and need to be replaced. The pump is cooled by water flowing through it, and will normally be at the temperature of the water being pumped.

- **Stuffing Box.** After a short period of operation verify that the stuffing box area and gland are not hot. If heating is detected, loosen the gland nuts evenly until water is just running out of the stuffing box in “droplet” form. Water must not be streaming or spraying out. Verify cool operation periodically. Adjust gland nuts evenly as necessary for lubrication and cooling of the packing. If packing is tightened to the limit of the packing gland travel, additional packing is necessary.

Mechanical Seal. Adjustment or maintenance is normally not required. The seal is enclosed within the pump and is self adjusting. Seal is cooled and lubricated by the liquid being pumped. Do not run the pump dry!

Pump Protection - Cold weather /wet weather installations.

- **System Drains** - Provide drain valves to empty the system, including the pump case, to prevent freezing damage.
- **Shelter** - If possible, provide shelter for the unit to protect it from the weather. Allow adequate space around the pump unit for service. When effectively sheltered, a small amount of heat will keep the temperature above freezing. Provide adequate ventilation for the unit when running. For severe weather problems, or where other shelter is not practical, a totally enclosed fan cooled (TEFC) type motor should be considered.
- **Condensation** - When the temperature of the metal parts of a motor are below the dew point and the surrounding air is moist, water will condense on the metal surfaces which over time will cause corrosion damage. In severe conditions, a space heater should be considered to warm the motor unit.

5.13 The 3-Way Flow Valves - Inspection and Maintenance

The Turbo Disc system has been thoroughly tested at the factory. However at start up for the first time, verify the following:

- Water flow through the system in the Filter mode and Backflush mode are correct
- Air line pressure on the upper or lower diaphragm on the flow control main valves is correct.

Troubleshooting and General Maintenance.

Description: The Bermad Model 350 Backflush Remote Control Valve is designed to supply media filters or close supply drip-tight and backwash the media filters. This can be done in response to an electric or hydraulic signal. It functions in two modes; normally closed (supply shut with filters open to backflush) or normally open (backwash port shut with supply open to filters). Note - In the standard mode (or without any operating devices) the valve is normally open; a signal is required to close supply port. An automatic or manual control device alternately applies pressure into the upper diaphragm chamber to close the supply, or by venting pressure from the upper diaphragm chamber to open the supply main valve to feed the filters. See the note below for Bermad 2x2 and 3x3 valves which require both pressure and venting for proper operation.

Installation: Allow enough room around the valve assembly for making adjustments and for future maintenance and disassembly work. Thoroughly flush the pipeline to remove dirt, scale and debris. Failure to do this may render the valve inoperable. It is recommended that isolation gate valves be installed upstream and downstream of the control valve to allow for future maintenance operations.

Apply the proper sealant and /or gaskets to the end connections. Install the valve in the pipeline, with the valve flow arrow on the body casting, in the proper direction.

Install the valve horizontally with the cover up for best performance. Make certain the valve is positioned so the valve cover assembly can easily removed for future maintenance. After installation carefully inspect, or correct any damaged accessories, piping, tubing, or fittings. Tighten all fittings.

Startup Operation: Initially insure there is flow through the valves, system piping and filters. Insure that a downstream demand is created (a lower pressure to atmosphere). Verify the air compressor is operational and produces at least 140 psi, the connections to the electrical mains and system AC voltages are correct.

Next, open the manifold pipeline isolation valves, if applicable. On the main 3-way flow control valves, verify the upper diaphragm chamber is de-pressurized (vented) Likewise note that in the backflush mode the upper diaphragm chamber must be pressurized.

Note - On the Bermad 2x2 and 3x3 valves there are two diaphragm chambers. One chamber on the top cover and another on the side of the valve body. In this case, one chamber must be vented while the other chamber is pressurized or the valve will not operate in either the open or closed position.

Inspection and Maintenance: Weekly inspect the system and specifically the flow control valves for proper operation. Check for water leaks at the Victaulic couplings and in and around the flow control valves. Depending on the water effluent, or at least two times a year, inspect the rubber diaphragm and internal valve seats (seals) for wear and pitting. This periodic maintenance and inspection is done after the system has been shut down and de-pressurized. The bolts around the diaphragm chamber can be removed without taking the valve body out of the piping manifold. The rubber diaphragm and valve plunger can be removed for inspection and cleaning. Replace torn or damaged diaphragms and /or worn and pitted valve seats /plungers, as necessary. It is recommended that the flow valves be disassembled every two (2) years.

Troubleshooting: Refer to the 3-way Flow Valve Troubleshooting Chart below to diagnose valve symptoms.

3-Way Flow Valve Troubleshooting Chart

Symptom	Cause	Corrective action
Valve Fails to Open - Supply to Filters	Insufficient inlet pressure flow	Check or create inlet pressure flow
	Upper diaphragm chamber (Port A) is pressurized	De-pressurize the upper diaphragm chamber (port A) cover
	Valve plugged with debris	Remove valve body and clean
Valve fails to Close - Shut Supply Pressure and Back flush Filters	Debris trapped in main valve	Remove valve cover, diaphragm and spring to inspect internal seating area
	Diaphragm in main valve leaking	Replace the diaphragm
	Lower diaphragm side chamber (port B) is pressurized.	De-pressurize the lower diaphragm (port B) side of chamber. Note: Only available on the 2x2 and 3x3 models otherwise port must be vented.

Note: The following information on inspection and maintenance of flow control valves is from the Bermad 350 series User Manual (.pdf file) and is for basic troubleshooting only. Complete information on this and other flow control valve products can be found online.

5.14 MAXIM Controller - Setup and Troubleshooting

MAXIM Controller Settings: Prior to start-up, read and fully understand this *MAXIM Controller* section of the Manual. Turn on the controller by moving the switch to the “ON” position. Check the controller’s settings by scrolling through the menu screens. The settings are factory preset at nominal values, however, these may need to be adjusted to meet your system’s backflush needs.

Be sure the Pressure Differential setpoint is properly set once there is water flow. The recommended PD setpoint is 1-2 PSID above the “clean” gauge reading at the systems MAXIMUM flow rate. Setting this PD setpoint at low flow may result in continuous backflushing at higher flow rates, since the Pressure Differential increases with flow rate. Typical PD setpoints are between 3-6 PSID, depending on flow rate.

The following is a typical configuration of the Maxim 10 controller inputs and outputs.

CAUTION: Disconnect controller from power source before removing cover!

A. Outputs #1 - 7 control the backflush valves.

Output #8 is a relay output for the **System Alarm**. **Output #9** is an optional Air Override Valve control. **Output #10 (Backflush Master)** controls the Backflush Booster Pump or system sustaining valve to increase pressure during backflush.

- B. Inputs - #1** - The optional PD Switch monitors the Inlet and Outlet pressures of the system and in the event of an elevated Pressure Differential will signal the Maxim Controller to start a Backflush cycle. **Input #2** is the Backflush Timer enable input. If a Main Pump control is used, this input will enable the timed backflush whenever this pump is running. If the system is a Full Flow design an Inlet pressure switch will be used at this input to signal sufficient pressure to enable the Backflush timer.

- C. The Analog/Digital Input locations** allow Miller-Leaman Inc. to design customer specific programs. These programs are then able to receive and process both digital and analog signals from devices such as Pressure Transducers, Flow-meters, Level Switches, etc. **Inputs IC & ID** are the Inlet and Outlet Pressure Transducer connections. These provide a 0-10Vdc signal into the controller. These signals are converted into pressure level values and compared to each other for the pressure differential value. When the PD value exceeds the PD setpoint, the Maxim Controller is signaled to start a Backflush cycle.

Maxim Millennium III circuit board configuration

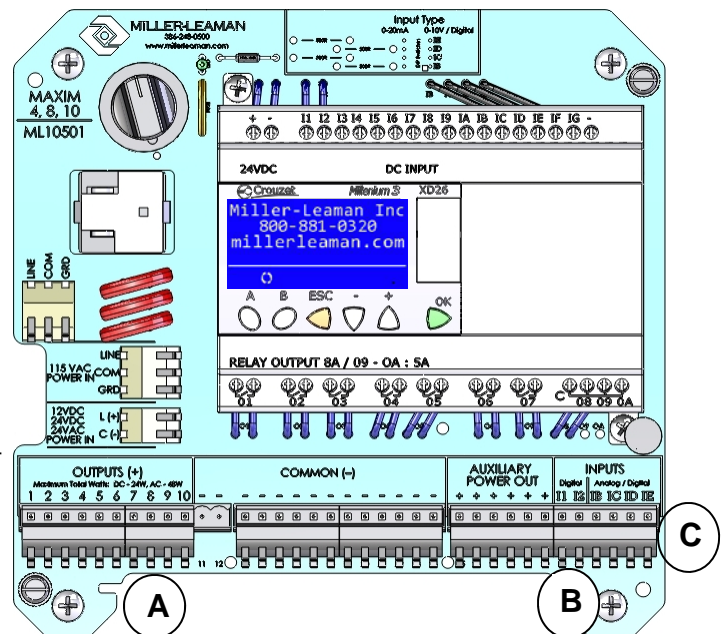

Electrical Connections:

NOTE: When using an external power source, the input power to the PC Board must be the same as indicated on the upper left side of the Maxim Controller. Typically the controller is either 24 volts AC or 24 volts DC, however some controllers use 120 volts AC, or 12 volts DC.

Each filter station solenoid is connected to a corresponding *Output (+)* and *Common (-)* terminal on the Maxim circuit board. The optional Pressure Differential Gauge and Timer ON Enable inputs are connected to a corresponding Input and Auxilliary Power Out (+) terminal on the Maxim circuit board. The Pressure Transducers have a three wire connection, one assigned to the input (IC or ID), one to the *Common (-)* terminal, and the third to the Auxilliary Power Out (+) terminal .

Review the *Electrical Schematics in the Engineering Drawings* section prior to making any connections to the controller. If requested custom input/output capabilities are not described in this manual, please refer to an attached addendum.

Optional Differential Pressure Gauge Connections:

The Optional Pressure Differential (PD) gauge is connected to the system's inlet (high) and outlet (low) pressure ports.

WARNING: Failure to use a second wrench on the low pressure port when tightening fittings may result in damage to the internal pressure tubing.

Be sure all connection tubing is clean prior to installation on the gauge. The gauge contains orifices that may become clogged by larger particles.

CAUTION: Make sure not to foul the pressure orifices with pipe dope or dirt, as the gauge will not operate.

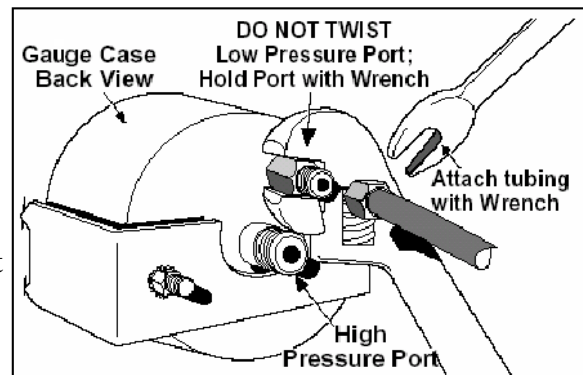

Optional Differential Pressure Gauge Set-point:

Adjust the front face needle contact to the desired PD set-point that will trigger a backflush cycle. The recommended PD setpoint is 1-2 PSID above the “clean” gauge reading at the systems MAXIMUM flow rate. Setting this gauge at low flow may result in continuous backflushing at higher flow rates, since the Pressure Differential increases with flow rate. Typical PD gauge setpoints are between 3-6 PSID, depending on flow rate.

Scrolling through Menu Screens

The *MAXIM* controller allows the operator to scroll through a selection of menu screens by pressing the **A** or **B** buttons. Press **A** to scroll backward to the previous menu or press **B** to scroll forward to the next menu. The LCD backlight will automatically turn on for 5 minutes when a button is pressed, thus allowing the operator to easily view the menus in low light situations.

Power Up Screen: Screen 8, the Company Information Screen, is the Power Up Screen. Each time the Maxim Controller is turned on, or when power is returned after a loss, this screen will be displayed for 15 seconds. The Company information Screen can be viewed by turning off the Maxim Controllers power, then turning it back on again.

After 15 seconds, Screen 8 will be changed to the Manifold Pressure Screen. The Manifold Pressure Screen displays the scaled and filtered transducer signals in PSI for both the Inlet Manifold, and the Outlet Manifold. Also displayed is the calculated Pressure Differential between the Inlet and Outlet Manifolds in PSI. The PSID is also displayed on the Status Screen.

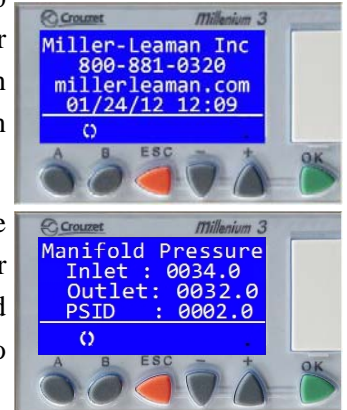

Press the **B** button to scroll forward to the **Status** screen.

The next section describes the menus in the order they are seen by scrolling with the **B** button from the Initial Power Up screen.



Screen 1 - Status



Screen 2 - BF Interval & PSID Setpoint

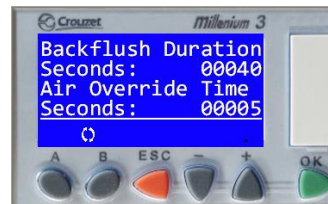

Screen 3 - BF Duration & Air Override time



Screen 4 - Pre-Dwell time & Dwell time



Screen 5 - Time Since Last BF & Triggered By

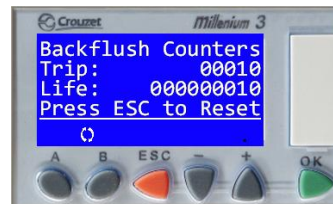

Screen 6 - BF Counters Trip & Life



Screen 7 - Machine & Controller ID

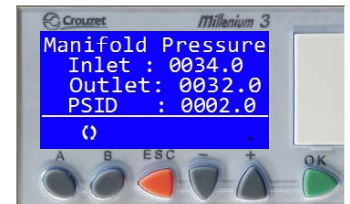

Screen 8 - Manifold Pressure

Note - pressing the **B** button to scroll forward from Screen 8 - Manifold Pressure screen, causes the display to cycle back around to the beginning and display the Screen 1 - Status screen. Also, pressing the **A** button to scroll backwards from Screen 1 - Status screen, causes the display to cycle back around to the end and display the Screen 8 - Manifold Pressure screen.

Changing Values

To change an adjustable value, first scroll to the appropriate menu screen using the **A** or **B** button. Follow the directions below to modify the value.

1. The current selected value will show flashing blocks. Use the + or - keys to select another value if desired.
2. Press **OK** on the selected value. The value will change from flashing blocks to flashing numbers.
(Flashing blocks indicate the value is locked into memory. Flashing numbers indicates the value is unlocked and can be changed.)
3. Press the + or - buttons to change the value.
(Holding the + or - button will allow the value to increase at a faster rate after the first 10 increments have passed.)
4. When finished, press **OK** to save the change to memory. The value will return to flashing blocks

The following screens contain values that are operator adjustable. The controller's factory preset values may not be the final operating values. These values should be adjusted to meet the filter's backflush requirements. Reference the filter manufacturer's owner's manual for further information.

Backflush Interval: The user-defined interval at which the system will initiate an automatic backflush cycle. The backflush Interval timer resets after any backflush cycle occurs (by timer, PD gauge, or operator). This value is adjustable from 1 minute to 1000 hrs. Setting both values to zero will turn off the backflush timer. It is recommended that the operator adjust the backflush interval timer so that the system backflushes by time before the pressure differential set-point is reached. Factory Preset value is 4 Hours.



PSID Setpoint: The Pressure Differential setting in PSI, which when compared to the calculated Differential Pressure from the Inlet and Outlet pressure transducers, will cause a Backflush cycle to begin when exceeded. The recommended PD setpoint is 1-2 PSID above the "clean" PSID reading at the systems MAXIMUM flow rate. Setting this PSID Setpoint at low flow may result in continuous backflushing at higher flow rates, since the Pressure Differential increases with flow rate. This value is adjustable from 1 to 30 PSID. Factory preset is 7 PSID.

Backflush Duration: The time allotted for each individual filter station to backflush. This time should be set according to the type of filter and the nature of the material being filtered. This value is adjustable from 5 to 300 seconds. Factory Preset value is 40 seconds.



Air Override Time: The amount of time that the *Air Override* solenoid turns on at the start of each filter station backflush. This value is adjustable from 5 to 300 seconds. Factory Preset value is 5 seconds.

Pre-dwell Time: The time allotted between the Backflush Master output signal and the first filter station backflush. This period allows time for the system to build pressure (via a Sustaining valve, booster pump, etc.) before backflushing begins. This value is adjustable from 0 to 300 seconds. Factory Preset value is 5 seconds. A *pre-dwell time* is only necessary when using the Backflush Master output..

Dwell Time: The amount of time allotted between the end of the backflush cycle for one filter station and the start of the backflush cycle for the next filter station in sequence. This value is adjustable from 0 to 300 seconds. Factory Preset value is 30 seconds.



Backflush Counters (Screen 6)

Trip: The number of backflush cycles that have occurred since the counter was last reset. This includes cycles initiated both manually and automatically. This counter can be reset by pressing the red **ESC** button from the *Backflush Counters* screen.

Life: The number of backflush cycles that have occurred in the controller's lifetime. This includes cycles initiated both manually and automatically. This counter cannot be reset.



Time Since Last Backflush: (Screen 5) This screen is READ ONLY for information and is not adjustable. The screen shows the amount of time that has elapsed since the system last backflushed (example: 00011:30 is 11 hours and 30 minutes) and how the last backflush was triggered. There are three trigger possibilities:

- 1) *Operator* - backflush triggered manually by an operator
- 2) *Timer* - the backflush was triggered by time as set on the Backflush Interval screen.
- 3) *PD gauge* - the backflush was triggered by a high pressure differential, as set on the PD gauge or pressure transducers.



The Status Screens

The Status screens provide system feedback, allowing the operator to monitor when and how the backflush cycle is occurring. A backflush cycle can be started manually, or automatically via the Backflush Interval Timer or the Pressure Differential Switch (PSID).

The current **Status** of the controller is displayed as follows:

1. **Status: OFF** - Indicates that the backflush interval timer is paused. The system will not backflush by the timer. There is assumed to be no flow going through the system. A backflush can still occur from a high pressure differential via the optional PD gauge, indicated as >> **High PSID** << on display, or manually by the operator by pressing the green OK button on the controller. The controller displays **Status: OFF** when there is no voltage present at input *I2* on the controller.

On Full Flow Systems, an inlet pressure switch is used to sense sufficient inlet pressure and allow for timed backflushes to occur. On these systems, when the switch senses inlet pressure is low, the backflush interval timer will be paused, and a timed backflush will not occur. The **Status** screen will display **Inlet Pressure Low**. A backflush can still occur from a high pressure differential via the optional PD gauge, indicated as >> **High PSID** << on the display, or manually by the operator by pressing the green OK button on the controller.

2. **Status: AUTO** - Indicates that the controller is waiting for a backflush cycle to begin. The system is assumed to be in normal filtration mode and flowing water. The backflush interval timer is running. The controller displays **Status: AUTO** when there is a voltage present at input *I2* on the controller, and a backflush cycle has not begun. A backflush can still occur from a high pressure differential via the Pressure Transducers, indicated as >> **High PSID** << on the display, or manually by the operator by pressing the green OK button on the controller.

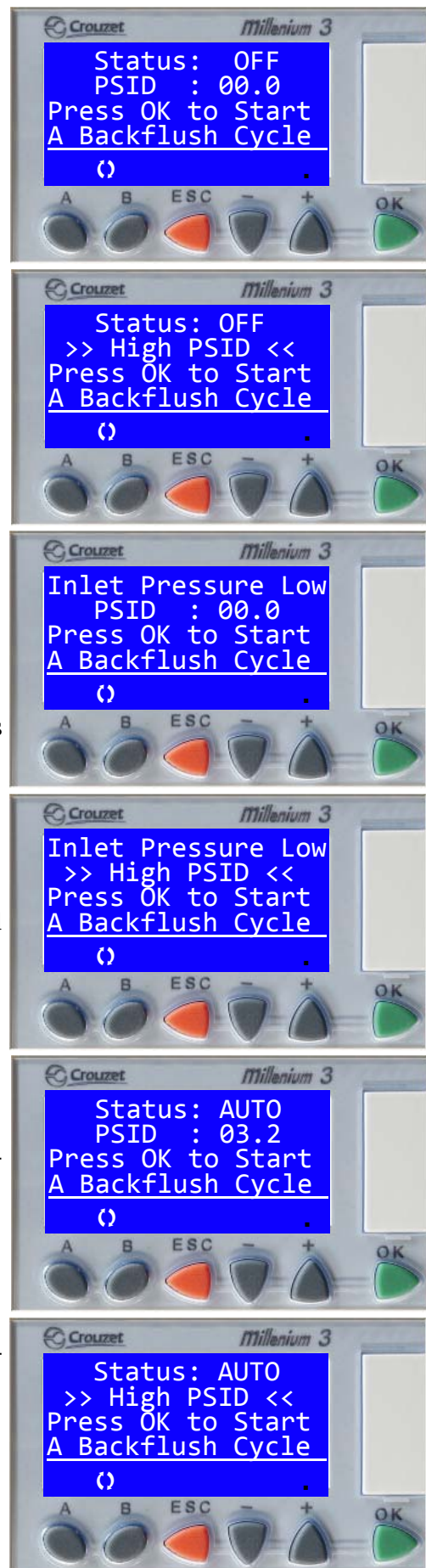

Status of the controller (continued)

- 3. **Status: ON** - Indicates that the system is in backflush mode, initiated either by the Operator, by the Backflush Interval Timer, or the Pressure Transducers. The controller will stop displaying the PSID value, but will instead indicate which station is currently in a backflush or dwell.

Pre-Dwell is displayed as soon as the Backflush cycle has begun. In systems without a Backflush Bypass Pump, the Backflush MASTER output is turned on. This is connected to the Pressure sustaining valve to allow for a back pressure to develop high enough for a proper backflush to occur. On systems with a Backflush Bypass Pump, this pump will be turned on to allow for a back pressure to develop high enough for a proper backflush to occur. This Pre-Dwell time is setup nominally for 5 seconds and adjusted on Setup screen #4. This output stays on throughout the entire backflush cycle. After this pre-dwell time, the back pressure will be sufficient and **#01 Backflush** will be displayed. This means that the first filter pod has been selected for backflushing, and its flow direction valves have started to change from the filtration position to the backflush position. At the same time the Air Override output is turned on for about 5 seconds. This provides additional air pressure to the top of the filter pods to assist with the backflush. The Backflush Duration is nominally set for 40 seconds. The Backflush Duration time and Air Override time are adjustable - see Setup screen #3 for information.

After this backflush duration time, **#01 Dwell** will be displayed. This means that the first filter pod backflushing is complete, and its flow direction valves have started to change from the backflush position to the filtration position. This period of time also allows for a re-buildup of back pressure in the system for the next backflush cycle. This Dwell time is setup nominally for 30 seconds and adjusted on Setup screen #4. After this dwell time, **#02 Backflush** will be displayed. The remaining filter pods will be backflushed in this same cycle pattern until all have been backflushed.

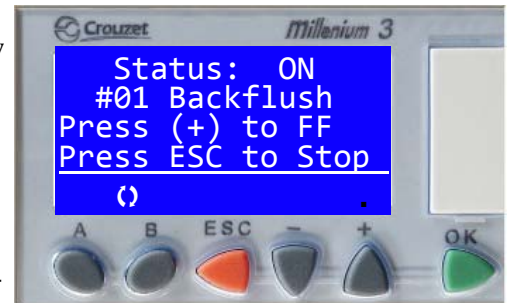

Status of the controller (continued)

3. Status: ON (continued)

After all filter pods have been backflushed the Backflush Master output will be turned off and the sustaining valve will open. The display will show the last filter pods number and **Dwell**. This means that the last filter pod's flow direction valves have started to change from the backflush position to the filtration position. After this dwell time, the backflush cycle is complete and **Status: AUTO** will be displayed.

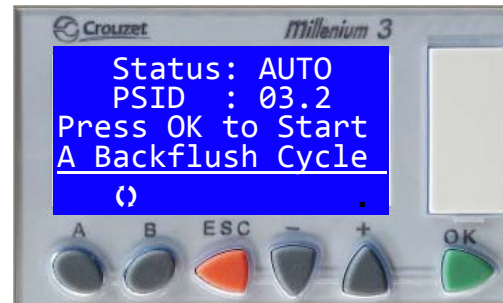

To initiate a manual backflush, press **OK** while on the status screen. To skip the current backflushing station, press **+** to "fast forward" to the next station. Note that holding the **+** button will hold the cycle in a dwell until it is released. At any time during the backflush cycle, press **ESC** to stop the cycle.

4. Status: System Alarm - On any of the Status screens, OFF, Inlet Pressure Low, AUTO, or ON, a System Alarm screen can be activated. The second line down will be alternately flashing **>> System Alarm <<** and whatever was on line 2 before the system alarm occurred.

A system alarm can be any customer specific alarm. The only standard system alarm is the **Consecutive Backflush Alarm**. This alarm occurs when the backflush cycle has been initiated three times in a row by the Pressure Transducers or optional Pressure Differential Switch (**PSID**). Normal operation will cause a timed backflush every four hours. (Nominal Backflush Interval Setting - see Setup Screen #2 for adjustment information) If the **PSID** input is on and calling for consecutive backflushes, or the Pressure Transducer values are indicating an excessive DP as compared to the individual Pressure Gauges, then the operator should verify proper setting and operation of the PSID, or Pressure Transducers as well as the wiring into the Maxim Controller. To reset the **Consecutive Backflush Alarm**, first, correct the cause of the alarm, then push the red ESC button on the controller while a Status screen is displayed.



5.15 Cleaning and Stainless Steel Maintenance.

Before the units leave the factory all of our filter systems are professionally cleaned using the Walter Surfox-203 stainless steel cleaning process to help prevent rust and corrosion. Even though all of our filter systems use 304, 316 and other stainless steels, they will still rust given enough time out in the elements and weather.

To clean the units, it is recommended that they be periodically washed with any one of the 3-in-1 car care washing detergents (wash and wax products sold at auto supply stores) and a green cleaning pad (ScotchBrite product) to remove the surface rust. After they are dry, applying mineral oil over all the surfaces will help protect the stainless steel from corrosion. Alternately, any one of the better marine anti-corrosion products (LPS and other manufacturers) that are sold at marine supply stores can be used on the units.

Section 6 - Troubleshooting Procedures

6.1 System Troubleshooting - Backflush Cycle Not Complete

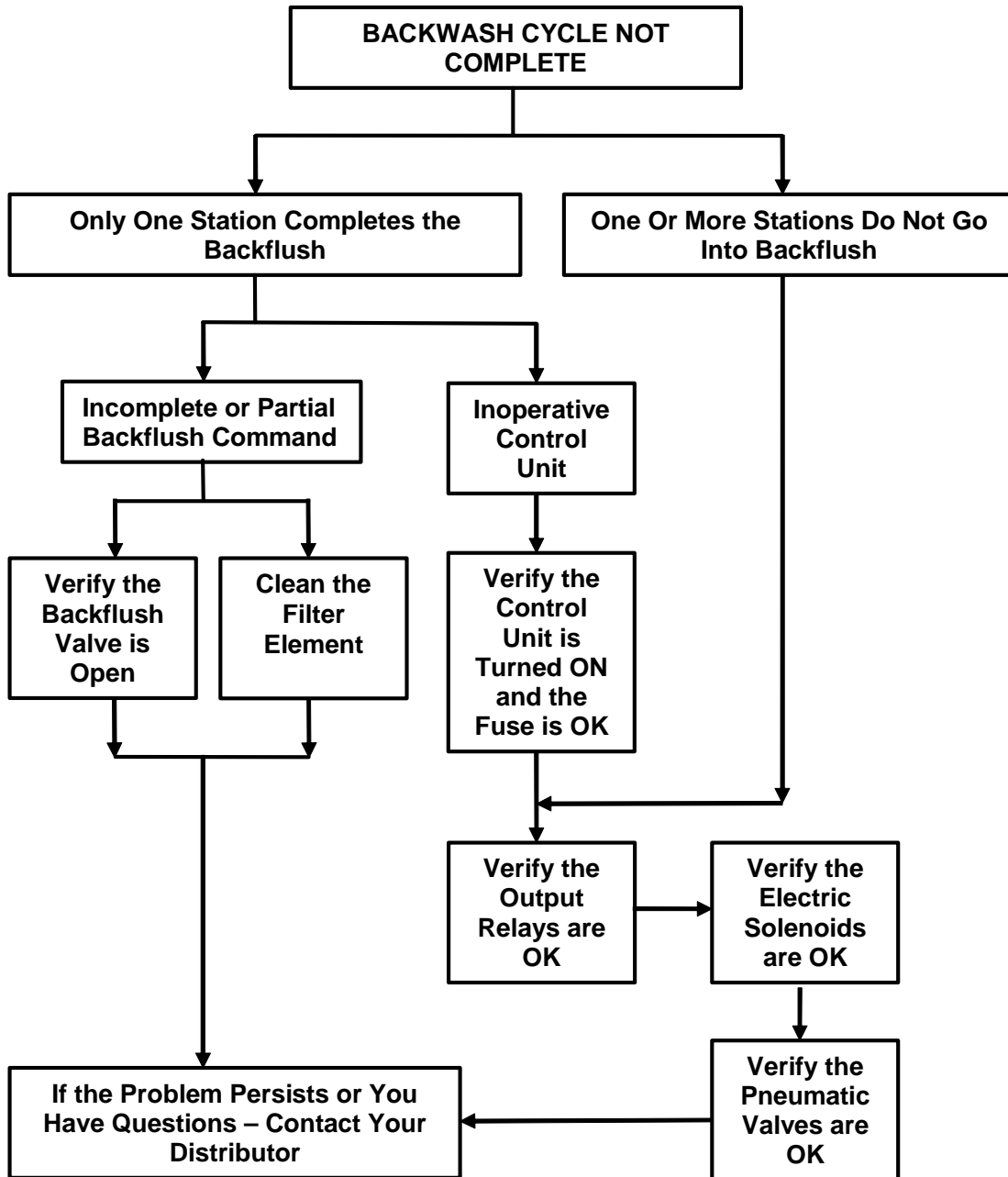

6.2 System Troubleshooting - Water in the Backflush Manifold

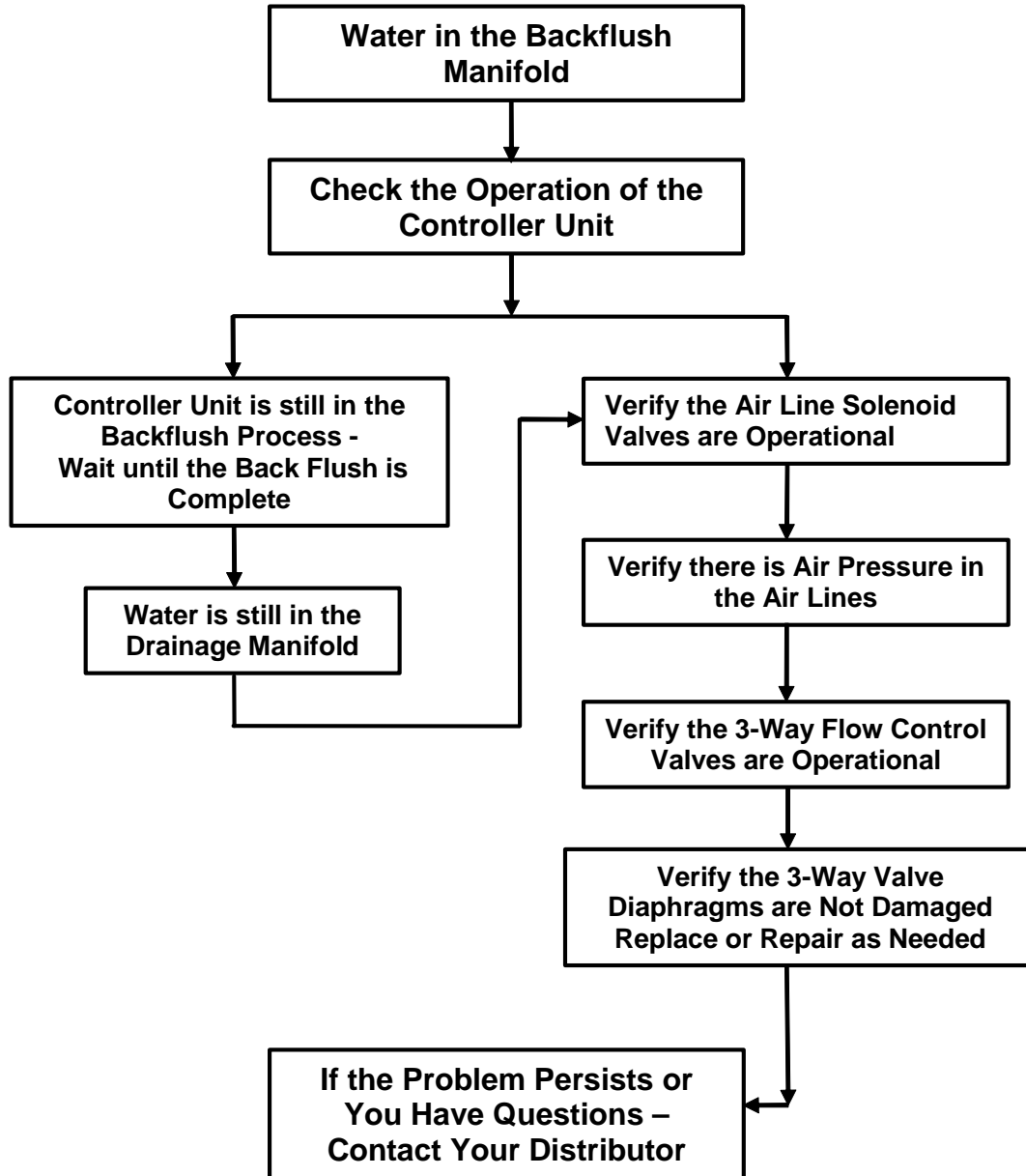

6.3 System Troubleshooting - Too Frequent Backflush Cycles , System Alarm - Consecutive Backflush Alarm

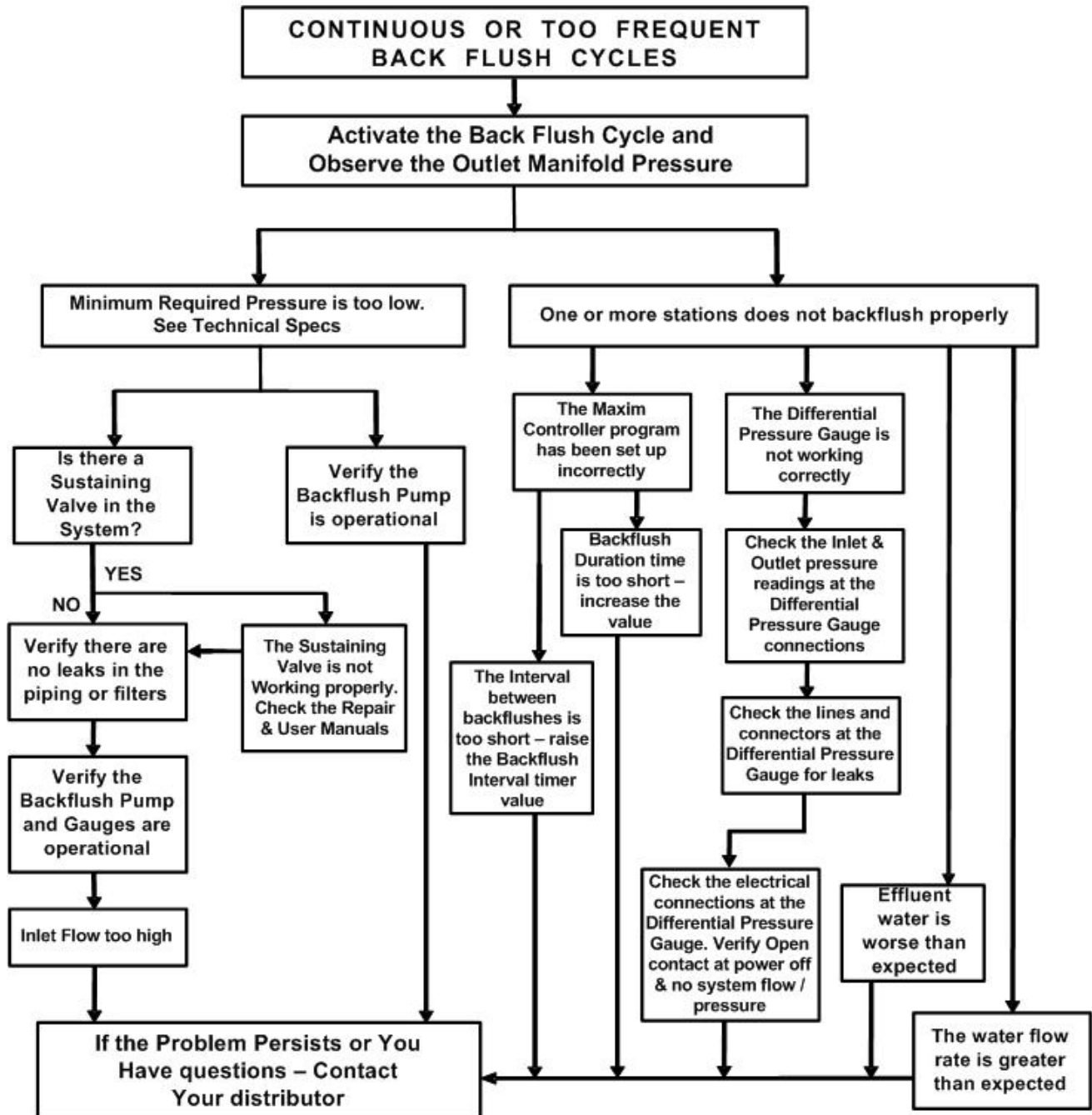

Section 7 - Appendix



TurboDisc Maintenance Work Log

TurboDisc description	
Serial Number	
Location	

Item	Maintenance Tasks	Check	Clean	Replace	Overhaul	Date	Initials
1							
2							
3							
4							
5							
6							
7							
8							
9							
10							
11							
12							
13							
14							
15							
16							
17							
18							
19							
20							
21							
22							
23							
24							
25							
26							
27							
28							
29							
30							



TurboDisc Maintenance Schedule Spring - Summer

Spring Tasks		Check	Clean	Overhaul	Date	Initials
First Quarter						
Monthly Tasks	Weekly Tasks	Check	Clean	Overhaul	Date	Initials
Month 1						
April	Week 1					
	Week 2					
	Week 3					
	Week 4					
Month 2						
May	Week 1					
	Week 2					
	Week 3					
	Week 4					
Month 3						
June	Week 1					
	Week 2					
	Week 3					
	Week 4					
Spring Tasks						
Second Quarter						
Monthly Tasks	Weekly Tasks	Check	Clean	Overhaul	Date	Initials
Month 4						
July	Week 1					
	Week 2					
	Week 3					
	Week 4					
Month 5						
August	Week 1					
	Week 2					
	Week 3					
	Week 4					
Month 6						
September	Week 1					
	Week 2					
	Week 3					
	Week 4					



TurboDisc Maintenance Schedule Fall - Winter

Fall Tasks		Check	Clean	Overhaul	Date	Initials
Third Quarter						
Monthly Tasks	Weekly Tasks	Check	Clean	Overhaul	Date	Initials
Month 7						
October	Week 1					
	Week 2					
	Week 3					
	Week 4					
Month 8						
November	Week 1					
	Week 2					
	Week 3					
	Week 4					
Month 9						
December	Week 1					
	Week 2					
	Week 3					
	Week 4					
Winter Tasks						
Fourth Quarter						
Monthly Tasks	Weekly Tasks	Check	Clean	Overhaul	Date	Initials
Month 10						
January	Week 1					
	Week 2					
	Week 3					
	Week 4					
Month 11						
February	Week 1					
	Week 2					
	Week 3					
	Week 4					
Month 12						
March	Week 1					
	Week 2					
	Week 3					
	Week 4					

Page intentionally left blank

Section 8 - Replacement Parts List

Page intentionally left blank

Section 9 - Engineering Drawings

Page intentionally left blank

Section 10 - Bill of Material

Page intentionally left blank

Warranty

Miller-Leaman warrants its products against defects in material and workmanship under normal use and service for which such products were designed for a period of twelve (12) months after shipment from our factory. Our sole obligation under this warranty is to repair or replace, at our option, any product or any part or parts thereof we find to be defective. **SELLER MAKES NO OTHER REPRESENTATIONS OR WARRANTIES, EXPRESS OR IMPLIED, INCLUDING, BUT NOT LIMITED TO, ANY IMPLIED WARRANTY OF MERCHANTABILITY OR FITNESS FOR A PARTICULAR PURPOSE.** The warranty set forth above is the only warranty applicable to Miller-Leaman products. Our maximum liability shall not in any event exceed the contract price for the product. **IN NO EVENT SHALL MILLER-LEAMAN BE LIABLE FOR ANY DELAY, WORK STOPPAGE, CARTAGE, SHIPPING, LOSS OF USE OF EQUIPMENT, LOSS OF TIME, INCONVENIENCE, LOSS OF PROFITS OF ANY DIRECT OR INDIRECT INCIDENTAL OR CONSEQUENTIAL LOSS OR DAMAGES RESULTING FROM OR ATTRIBUTABLE TO THE USE OF THE PRODUCT.** This warranty is governed by the Laws of the State of Florida. Venue and jurisdiction of any case or controversy related to the use of this product or this warranty shall lie exclusively in the State Courts of Volusia County, Florida.



Important Contacts

Miller-Leaman, Inc.

Main Office (United States)
800 Orange Avenue
Daytona Beach, FL 32114
Toll Free: (800) 881-0320
Local Phone: (386) 248-0500
Facsimile: (386) 248-3033
E-Mail:
sales@millerleaman.com
Internet:
www.millerleaman.com

Local Representative

Affix System Label Here

If a system Label is not affixed, record the *Turbo-Disc* Filtration System serial number in the space below. The serial number is located on the System Identification Label.

Serial # TD-_____