

Excalibur®

The **DFT® Excalibur Silent Check Valve** is a spring-assisted, center guided, non-slam check valve that provides reliable, low-maintenance service for a wide range of fluids and pressure/temperature combinations. The valve consists of a body, gasket, seat, spring, disc with stem and guide bushing. Excalibur check valves are available in a wide range of sizes and pressure ratings and in a variety of metals to meet most check valve requirements.



FEATURES:

- ASME B16.10 Face-to-Face dimensions
- Spring-assisted silent closing, non-slam
- 2" to 24" Line size
- ASME Class 150 to 1500 (See chart)
- Standard body materials:
 - A216 Grade WCB carbon steel
 - A351 CF8M stainless steel
- Optional body materials:
 - Alloy 20
 - Duplex SS
 - Hastelloy®
 - Inconel® 600
 - Monel®
- Nickel-Aluminum Bronze (See page 40)
- Standard ends:
 - RF Flanged
- Optional ends (4):
 - Butt weld
 - Flanged x Butt weld
 - RTJ
 - Victaulic®
- Stainless steel trim
- Center-guided
- Dual-guided stem
- Horizontal or vertical installation
- Tight shutoff
- Two-piece body
- Protected spring
- Easy maintenance
- Versatile
- Axial flow
- Nozzle style
- Options:
 - Soft seat
 - Inconel® X-750 Spring
 - Custom sizing low flow
 - Severe service trim
 - Stellite® trim
 - NACE (See page 43)

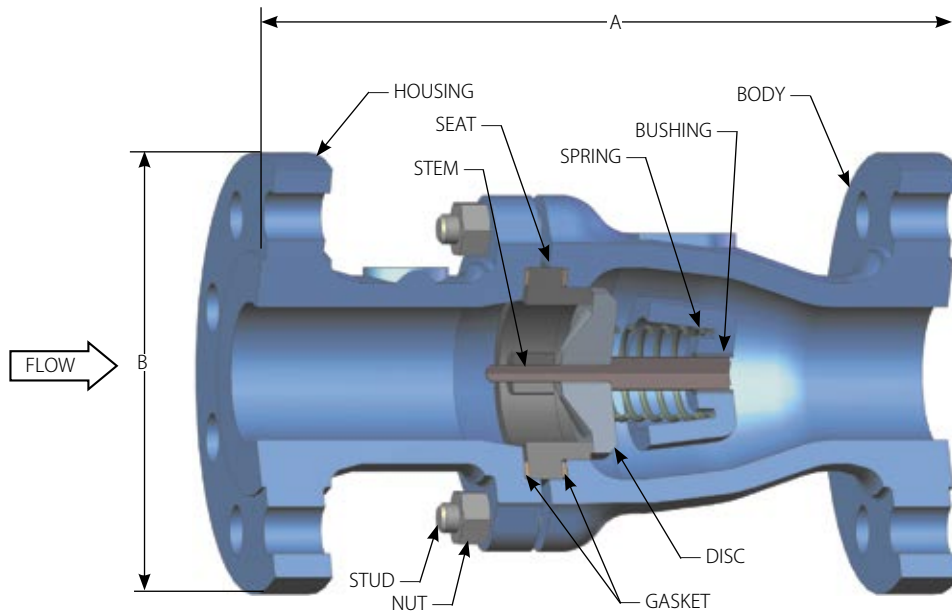

Consult pages 44 and 45 for Pressure/Temperature ratings and soft seat materials.

Excalibur®

MATERIALS OF CONSTRUCTION

COMPONENT	CARBON STEEL BODY	STAINLESS STEEL BODY
Body	A216 Grade WCB	A351 CF8M
Disc/Stem Assembly	A351 CF8M/A479 316	A351 CF8M/A479 316
Seat	A351 CF8M	A351 CF8M
Spring (1)	A313 316	A313 316
Bushing	A479 316	A479 316
Bolting (2)	A193-B7 (Stud) & A194-2h (Nut)	
Gasket (3)	Cl. 150 & 300	Corrugated Flexible Graphite
	Cl. 600+	316 Spiral wound with Flexible Graphite Filler

Class	150 RF	300 RF	600 RF	900 RF	1500 RF	
2"	A	8	10.50	11.50	14.50	14.50
	B	6	6.50	6.50	8.50	8.50
	Weight	22	29	35	81	81
	Cv	65	65	65	51	51
2 1/2"	CP	0.64	0.64	0.64	0.85	0.85
	A	8.50	11.50	*	*	*
	B	7.00	7.50			
	Weight	30	42			
3"	Cv	105	105			
	CP	0.44	0.37			
	A	9.50	12.50	14	15	18.50
	B	7.50	8.25	8.25	9.50	10.50
4"	Weight	32.5	52	69	100	158
	Cv	155	155	155	138	109
	CP	0.26	0.26	0.26	0.22	0.28
	A	11.50	14	17	18	21.50
6"	B	9	10	10.75	11.50	12.25
	Weight	64	92	139	176	267
	Cv	265	265	265	242	187
	CP	0.60	0.41	0.51	0.58	0.74
8"	A	14	17.50	22	24	27.75
	B	11	12.50	14	15	15.50
	Weight	114	181	300	498	780
	Cv	685	685	584	512	512
10"	CP	0.40	0.40	0.73	0.83	0.83
	A	19.50	21	26	29	32.75
	B	13.50	15	16.50	18.50	19
	Weight	207	294	481	638	1270
12"	Cv	1050	1050	985	777	777
	CP	0.58	0.60	0.67	0.54	0.83
	A	24.50	24.50	31	33	39
	B	16	17.50	20	21.50	24.31
14"	Weight	377	462	981	1650	1890
	Cv	1650	1650	1650	1449	1240
	CP	0.52	0.52	0.47	0.58	0.53

Class	150 RF	300 RF	600 RF	900 RF	1500 RF	
12"	A	27.50	28	33	38	*
	B	19	20.50	22	24	
	Weight	457	696	1218	1925	
	Cv	2400	2400	2400	1190	
14"	CP	0.53	0.53	0.50	0.53	
	A	31	33	35	*	*
	B	21	23	23.75		
	Weight	642	725	1549		
16"	Cv	3600	3600	*		
	CP	0.28	0.28	*		
	A	34	34	39	44.5	*
	B	23.50	25.50	26.94	27	
18"	Weight	825	1337	2250	2534	
	Cv	5200	5200	*	*	
	CP	0.51	0.51	*	*	
	A	38.50	38.50	*	*	*
20"	B	25	28.00			
	Weight	1225	1900			
	Cv	6250	6250			
	CP	0.50	0.50			
22"	A	38.50	40	47	52	*
	B	27.50	30.50	32	33.75	
	Weight	1500	2375	4338	5220	
	Cv	7850	7850	*	6240	
24"	CP	0.50	0.50	0.66	0.82	
	A	51	53	55	*	*
	B	32	36	37		
	Weight	2450	4110	6670		
26"	Cv	11300	11310	11070		
	CP	0.42	0.42	0.42		

- Notes:**
- Inconel® X-750 spring is available.
 - Contact DFT for stainless steel or other bolting materials.
 - 316 graphite material.
- * Consult DFT for valve availability.

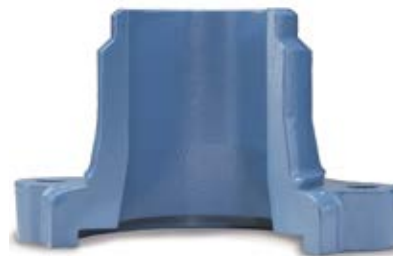

Optional butt weld end

All dimensions are in inches. Weights are in pounds. For metric measurements, visit www.dft-valves.com. CP: Cracking Pressure (psig)

FLANGED VALVES