

DEMING®

INSTALLATION, OPERATION & MAINTENANCE MANUAL End Suction Centrifugal Pumps For Chemical Process

Series: 3060

ANSI-B73.1

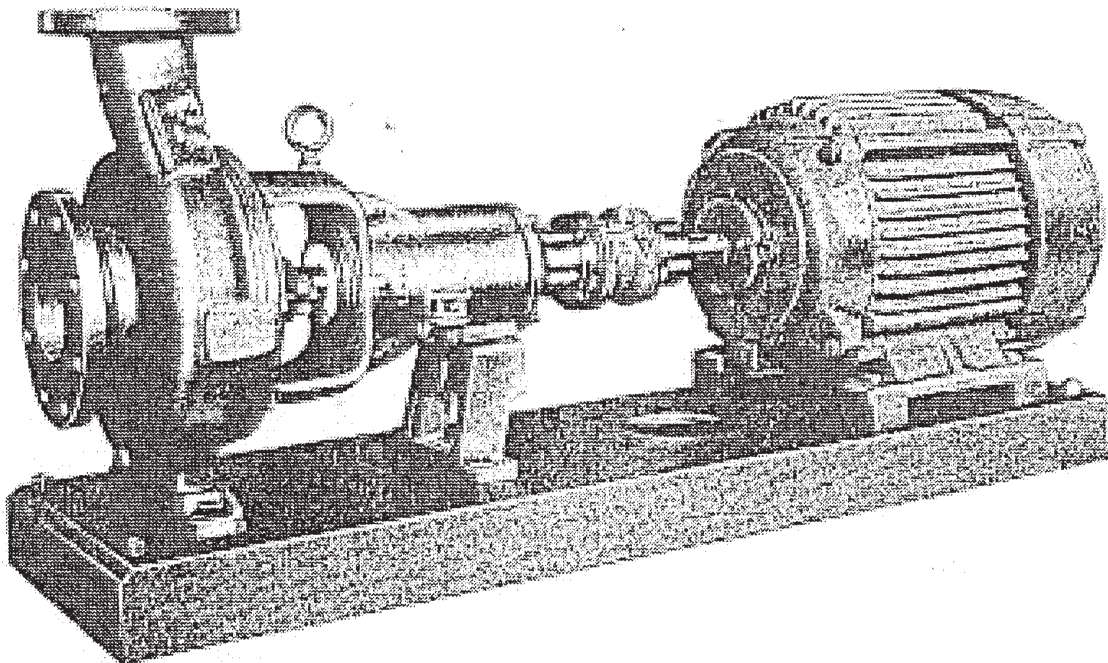

IMPORTANT!

*Read all instructions in this manual before operating pump.
As a result of Crane Pumps & Systems, Inc., constant product improvement program,
product changes may occur. As such Crane Pumps & Systems reserves the right to
change product without prior written notification.*

CRANE

A Crane Co. Company

PUMPS & SYSTEMS

420 Third Street
Piqua, Ohio 45356
Phone: (937) 778-8947
Fax: (937) 773-7157
www.cranepumps.com

83 West Drive, Brampton
Ontario, Canada L6T 2J6
Phone: (905) 457-6223
Fax: (905) 457-2650

Form No. 119987-Rev. D

CONTENTS

SAFETY FIRST	3
A. GENERAL INFORMATION.....	4
Receiving, Storage, Service Centers	
B. INSTALLATION	4 - 7
Foundation, Mounting, Field Alignment, Grouting, Piping	
Wiring, Rotation, Cooling, Lubrication	
C. OPERATION.....	7
Priming, Starting, Adjustment	
D. MAINTENANCE	7 - 12
Inspection, Lubrication, Impeller Adjustment, Packing Box Care,	
Disassembly, Reassembly	
E. LOCATING TROUBLE	13
CROSS-SECTIONS & PARTS LIST.....	14 - 16
WARRANTY & RETURNED GOODS	17

SAFETY FIRST!

Please Read This Before Installing Or Operating Pump. This information is provided for **SAFETY** and to **PREVENT EQUIPMENT PROBLEMS**. To help recognize this information, observe the following symbols:



IMPORTANT! Warns about hazards that can result in personal injury or Indicates factors concerned with assembly, installation, operation, or maintenance which could result in damage to the machine or equipment if ignored.

CAUTION! Warns about hazards that **can or will cause minor** personal injury or property damage if ignored. Used with symbols below.

WARNING! Warns about hazards that can or will cause serious personal injury, death, or major property damage if ignored. Used with symbols below.



Hazardous fluids can cause fire or explosions, burns or death could result.



Extremely hot - Severe burns can occur on contact.



Biohazard can cause serious personal injury.



Hazardous fluids can Hazardous pressure, eruptions or explosions could cause personal injury or property damage.



Rotating machinery Amputation or severe laceration can result.



Hazardous voltage can shock, burn or cause death.

Only qualified personnel should install, operate and repair pump. Any wiring of pumps should be performed by a qualified electrician.

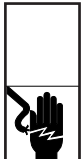

WARNING! To reduce risk of electrical shock, pumps and control panels must be properly grounded in accordance with the National Electric Code (NEC) or the Canadian Electrical Code (CEC) and all applicable state, province, local codes and ordinances. Improper grounding voids warranty.



WARNING! To reduce risk of electrical shock, always disconnect the pump from the power source before handling or servicing. Lock out power and tag.



WARNING! Operation against a closed discharge valve will cause premature bearing and seal failure on any pump, and on end suction and self priming pump the heat build may cause the generation of steam with resulting dangerous pressures. It is recommended that a high case temperature switch or pressure relief valve be installed on the pump body.



CAUTION! Pumps build up heat and pressure during operation-allow time for pumps to cool before handling or servicing.



WARNING! Do not pump hazardous materials (flammable, caustic, etc.) unless the pump is specifically designed and designated to handle them.



WARNING! Do not wear loose clothing that may become entangled in moving parts.



WARNING! Keep clear of suction and discharge openings. **DO NOT** insert fingers in pump with power connected.



Make sure lifting handles are securely fastened each time before lifting. **DO NOT** operate pump without safety devices in place. Always replace safety devices that have been removed during service or repair. Secure the pump in its operating position so it can not tip over, fall or slide.



WARNING! To reduce risk of electrical shock, all wiring and junction connections should be made per the NEC or CEC and applicable state or province and local codes. Requirements may vary depending on usage and location.



WARNING! Products returned must be cleaned, sanitized, or decontaminated as necessary prior to shipment, to insure that employees will not be exposed to health hazards in handling said material. All Applicable Laws And Regulations Shall Apply.



Crane Pumps & Systems, Inc. is not responsible for losses, injury, or death resulting from a failure to observe these safety precautions, misuse or abuse of pumps or equipment.

A - GENERAL INFORMATION

TO THE PURCHASER:

Congratulations! You are the owner of one of the finest pumps on the market today. These pumps are products engineered and manufactured of high quality components. With years of pump building experience along with a continuing quality assurance program combine to produce a pump which will stand up to the toughest applications.

Check local codes and requirements before installation. Servicing should be performed by knowledgeable pump service contractors or authorized service stations.

RECEIVING:

Upon receiving the pump, it should be inspected for damage or shortages. If damage has occurred, file a claim immediately with the company that delivered the pump. If the manual is removed from the crating, do not lose or misplace.

STORAGE:

Short Term - Pumps are manufactured for efficient performance following long inoperative periods in storage. For best results, pumps can be retained in storage, as factory assembled, in a dry atmosphere with constant temperatures for up to six (6) months. Rotate shaft by hand approx. every 30 days.

Long Term - Any length of time exceeding six (6) months, but not more than twenty four (24) months. The units should be stored in a temperature controlled area, a roofed over walled enclosure that provides protection from the elements (rain, snow, wind blown dust, etc..), and whose temperature can be maintained between +40 deg. F and +120 deg. F. Pump should be stored in its original shipping container and before initial start up, rotate shaft by hand to assure seal and impeller rotate freely approx. every 30 days.

SERVICE CENTERS:

For the location of the nearest Deming Service Center, check your Deming representative or Crane Pumps & Systems Service Department in Piqua, Ohio, telephone (937) 778-8947 or Crane Pumps & Systems Canada, Inc., Brampton, Ontario, (905) 457-6223.

B - INSTALLATION

1. FOUNDATION

The pump foundation should be sufficiently substantial to form a level, rigid support for the combined weight of the pump and driver and maintain alignment of the installed unit. Foundation bolts, of the proper size, should be imbedded in the concrete. A pipe sleeve, about 2½" diameters larger than the bolt, should be used to allow for final positioning of the bolts. See Figure 1. Rough up area covered by the baseplate for good grout bond.

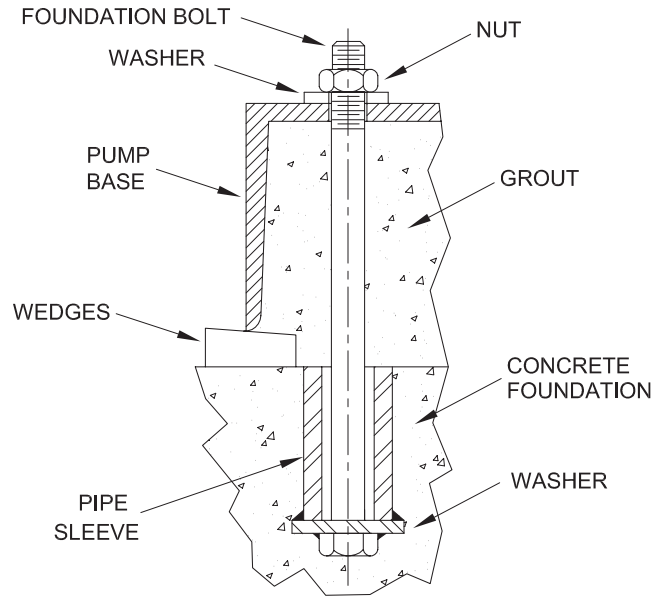

Figure 1. Foundation Bolt Location and Anchorage

2. MOUNTING:

Pumps and drivers that are received from the factory with both machines mounted on a common base plate, were accurately aligned before shipment. All baseplates are flexible to some extent and, therefore, must not be relied upon to maintain the factory alignment. Preliminary alignment is necessary after the complete unit has been leveled on the foundation, and again, after the unit is piped, and rechecked periodically as outlined in the following paragraphs.

Position unit on foundation and level the base plate, using rectangular metal blocks and shims, or wedges having a small taper as shown in Figure 1. A gap of ¾" to 1½" should be allowed between the base plate and foundation for grouting.

Adjust the metal supports or wedges until the shafts of the pump and driver are level. Check the coupling faces, as well as the suction and discharge flanges of the pump for horizontal or vertical position by means of a level. Correct the positions, if necessary, by adjusting the supports or wedges under the base plate, as required.

NOTE: A flexible coupling should not be used to compensate for misalignment of the pump and driver shafts. The purpose of the flexible coupling is to compensate for temperature changes and to permit end movement of the shafts without interference with each other, while transmitting power from the driver to the pump.



CAUTION! - Remove and lock out power to driver.

3. GROUTING

Grouting compensates for unevenness in the foundation and prevents vibration and shifting after mounting is complete. Build a form around the base plate to contain the grout, and sprinkle area with water to obtain a good bond. The base should be completely filled with a good quality, non-shrinking grout. The usual mixture for grouting is one part Portland cement and two parts sand with sufficient water to flow freely. It is also desirable to grout the leveling pieces, shims or wedges in place. Foundation bolts should be fully tightened when grout has hardened, usually about 48 hours after pouring.

4. FIELD ALIGNMENT

Figure 3060 Series units are normally furnished with a spacer coupling to allow for servicing the pump rotating assembly without removal of the pump casing, piping or driver from the baseplate.

After baseplate has been leveled and bolted to the foundation, the shafts of pump and driver must be realigned as misalignment may cause premature failure of the pump and driver bearings.

Remove the spacer segment from the coupling, see manufactures instructions and check for parallel and angular alignment as follows:

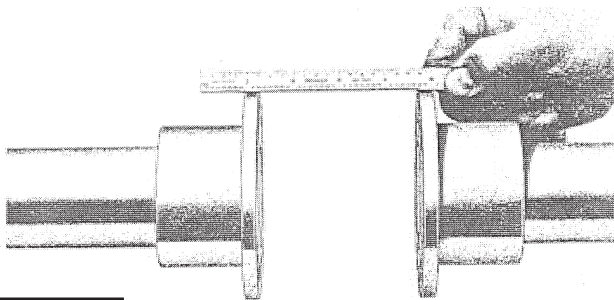

Figure 2

PARALLEL ALIGNMENT

Place a 6" scale or straight edge across the flanges of the coupling hubs, keeping the scale parallel with the shaft, check 4 points, 90° apart. By means of thin metal shims, adjust the driver until the shafts are parallel (see Figure 2).

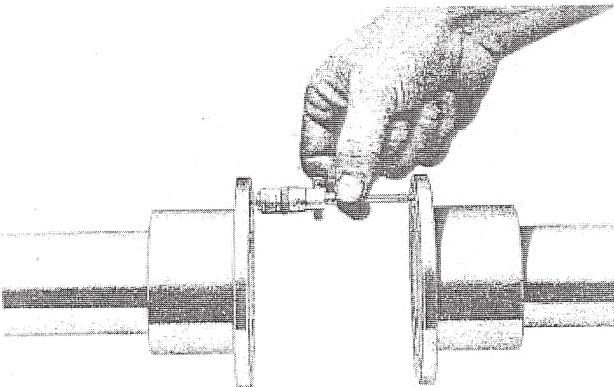

Figure 3

ANGULAR ALIGNMENT

Insert an inside micrometer between the hub faces at 90° intervals or rotate one hub 360° while taking readings from the other hub. By means of thin metal shims, adjust the driver until the faces are parallel (See Figure 3).

After each change it is necessary to recheck both parallel and angular alignment as adjustment in one direction may disturb adjustments made in another direction.

The permissible amount of coupling misalignment will vary with the type of pump and driver, but should be limited to approximately .002 inches per inch of shaft diameter when final adjustment is made.

When the units are lined up cold, it is necessary to make allowance for the vertical rise of the driver caused by any heating when in operation.

When the preliminary alignment has been completed the foundation bolts should be tightened evenly but not too firmly. Before replacing coupling segment connect piping to pump flanges and check motor rotation.

NOTE: Parallel and angular alignment must be checked again after piping is connected to the pump and any misalignment corrected. The coupling spacer segment can then be reinstalled in the coupling.



WARNING - Coupling guards must be used to avoid serious injury to operating personnel.

5. PIPING

The pump suction and discharge connections are not intended to indicate the required suction and discharge pipe sizes. The pipe diameter must be selected according to the requirements of the pumping system and recommended friction losses for the liquid being pumped.

Usually, it is advisable to increase the size of both the suction and discharge pipes at the pump nozzles to have minimum acceptable friction loss, suction pipe should never be smaller in diameter than the pump suction nozzle. When suction pipe is of larger diameter than the pump suction nozzle, an eccentric reducer is required to eliminate possible air or vapor pockets at the pump suction inlet.

Both suction and discharge pipes must be supported independently near the pump, so that when piping is connected to the pump, no strain will be transmitted to the pump. Piping should be arranged with as few bends as possible, and, preferably, with long radius elbow whenever possible.

SUCTION PIPING

A horizontal suction line must have a gradual rise to the pump. Any high point in the suction pipe can become filled with air and prevent proper operation of the pump and may cause loss of prime. The pipe and fittings must be free of all air leaks.

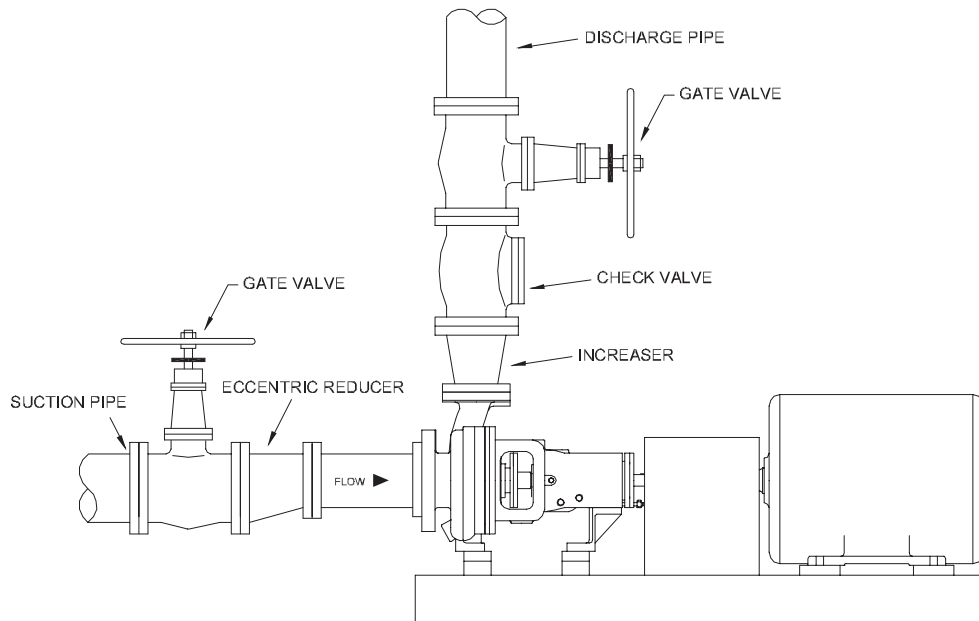

Figure 4

Any valves or fittings should be located at a distance equal to 5 to 10 times the diameter of the suction pipe from the pump suction nozzle. If an elbow must be installed at the pump suction, it should be installed in a vertical position to reduce unequal flow into the pump, which may cause cavitation in the pump.

NOTE: A gate valve in the suction piping should not be used as a throttling device, as this may cause the liquid to overheat during operation.

6. WIRING

For electric motor drives, connect power supply to conform with national and local codes. Line voltage and wire capacity must match the ratings stamped on the motor nameplate.

7. ROTATION

Before starting the pump, check the required direction of rotation of the pump. The proper direction is indicated by a direction arrow on the pump casing. Separate the coupling halves, then start motor to see that it rotates in the direction required by the pump. If it does not, reverse any two main leads of the 3-phase wiring to the motor. The coupling halves can be reconnected and the pump primed for starting.

8. COOLING

If pumps are fitted for high temperature application with cooling of the packing box cover (11) and frame (19). Connect water lines to the packing box cover and frame for cooling.

JACKETED PACKING BOX COVER

Connect cooling liquid piping to the lower (inlet) tap and exit through the upper tap; 3/8" on Fig. 3062, 1/2" on Fig. 3065, 1/2" on Fig. 3066. The 1/2" tap in the top of the jacket is for venting air before start-up. The 1/2" tap in the bottom of the jacket is for drain.

HIGH TEMPERATURE FRAME

Connect cooling liquid to the pipe tap in the side of the frame at the coupling end; 3/8" on Fig. 3062, 1/2" on Fig. 3065 and 3066, and outlet pipe on the opposite side. The pipe tap in the bottom is for drain or temperature sensing device.

Cooling liquid must flow slowly and constantly, at the required rate, to provide adequate cooling.

9. LUBRICATION

a. **Oil Lubricated Bearings** - Pumps furnished with oil lubricated bearings are shipped **WITHOUT** oil in the frame (19). To fill the oil reservoir in the frame:

1. Install the Trico Opto-Matic constant level oiler (77) on the frame as shown with the moveable oiler body at its lowest position. Unscrew the plastic bottle from the oiler and remove breather (235) from the frame (19). Fill bottle of the oiler and screw it onto the lower reservoir. Several fillings of the bottle will be required before the oil level in the bearing reservoir is equal to the level for which the oiler is adjusted. **NEVER FILL FRAME RESERVOIR THRU LOWER RESERVOIR OF THE OILER.** See LUBRICATION, Section D, for recommended lubricants. When proper oil level is obtained, refill and replace the plastic bottle on the oiler, also replace the breather (235) in the top of the frame.

b. **Grease Lubricated Bearings** - Grease lubricated bearings are pre-lubricated at the factory before shipment. See LUBRICATION, Section D, for recommended lubricants.

- c. **Packing Box Cover** - The pump may be furnished with packing or mechanical shaft seal as ordered. Packing must be continuously lubricated by suitable grease through grease fitting or with compatible liquid through tapping opening provided, from the casing (1) or from outside source.

Mechanical shaft seals must be lubricated depending on type of seal furnished. See LUBRICATION, Section D, for recommended lubrication.

- d. **Other Lubrication** - For proper lubrication of driver bearings and shaft couplings, See manufactures instructions.

C - OPERATION

The following important items should be checked as pump is started and placed in operation.

- a. Pump and driver securely bolted
- b. Coupling properly aligned
- c. Piping complete
- d. Correct pump rotation
- e. Pump shaft turns freely
- f. Discharge valve closed
- g. Suction valve open (if used)
- h. Coupling Guard installed
- i. Pump fully primed
- j. Pump and driver properly lubricated

Only after these items have been checked should the pump be started.

1. PRIMING

CAUTION: Before starting the pump, the casing and suction line must be filled with liquid, and air-vented through the vent pipe plugs. The pump must not be run until it is completely filled with liquid, because of danger of injuring some of the parts of the pump which depend upon liquid for lubrication. The discharge gate valve should be closed during priming. Be sure the mechanical seal and power frame are supplied with the proper lubrication. See LUBRICATION.

PRIMING BY SUCTION PRESSURE

When operating with suction pressure (flooded suction), remove the pipe plug at the top of the casing and when pump is filled with liquid, replace plug.

PRIMING WITH FOOT VALVE AND STRAINER

A foot valve and strainer may be installed on the lower end of the suction pipe to keep pump filled with liquid. Incorporate filler pipe in discharge pipe between pump and check valve. Remove pipe plug at top of casing, then fill suction pipe and pump with liquid. When pump is full of liquid, replace plug and close filler pipe.

CAUTION: When a foot valve and strainer are installed on the suction pipe, a spring loaded type check valve **MUST** be installed next to the pump in the discharge piping to prevent pump rupture from water hammer shock.

Priming by means of primer pump or ejector, attached to the pump, will also remove air from suction pipe and pump casing. When pump is filled with liquid, start motor and slowly open discharge gate valve.

2. STARTING THE PUMP

On initial start up, the gate valve in the discharge piping should be closed and slowly opened after pump is up to speed and pressure developed. **DO NOT** operate pump for any appreciable length of time against a closed discharge valve, as this may heat trapped liquid excessively and damage the pump or seal.

3. PUMP ADJUSTMENT

Open discharge valve as soon as operating speed has been reached. After the pump has been started the packing box glands should be tightened to eliminate excessive liquid loss. (Applies only to pumps having packed stuffing boxes.) Packing should not be pressed too tight, as this may result in burning the packing and scoring the shaft or shaft sleeve. The best adjustment will allow the liquid to drip slowly from the packing box gland. This will permit proper lubrication of the shaft and dissipate generated heat.

As soon as the pump and driver have reached the normal operating temperature, the unit should be shut down for final coupling alignment. This should be done by following the instructions found in Section B, Part 4. If correction is necessary, it may be accomplished by the addition or removal of shims from under the motor mounting feet.

D. MAINTENANCE

1. INSPECTION

Periodic inspection should be made of the following components:

- a. Bearing lubrication. Make sure the proper grade and amount of lubrication is present. Section B and Section D.
- b. Packing should be lubricated with the proper amount and type of acid-resistant lubricant.
- c. A double seal should be lubricated with light oil, clean water, or other compatible lubricating liquid.
- d. All piping connections, gasketed joints and drains should be checked for leaks.
- e. Check bearings for excessive wear or failure. Worn bearings may result in shaft run-out requiring frequent replacement of packing or seal
- f. Coupling alignment and lubrication must be maintained for smooth operation and long coupling life.

2. LUBRICATION

All pump and component parts have been lubricated at the factory except pumps with oil lubricated bearings which must be lubricated by filling oil reservoir through the constant level oiler, See Section B, item 9.

Subsequent lubrication depends on operating conditions. Periodic inspection of bearing lubrication is necessary and additional grease or oil should be added as required.



CAUTION: DO NOT over grease bearings or add excess oil

The following lubricants are recommended at the operating temperature indicated:

POWER FRAME

Oil lubricated Bearings:

- 0°F - 150°F, - S.A.E. #10 Wt. Non-detergent oil
- 150°F - 250°F, - S.A.E. #20 Wt. Non-detergent oil
- 250°F - 350°F - Dow Corning 4-3600

Grease Lubricated Bearings:

- 100°F - 40°F - Supermil M-125
- 40°F - 250°F - Shell Dolium R or Chevron SRI #2
- 250°F - 350°F - Supermill ASU M-100

Water Cooled Power Frame is recommended for temperatures above 350°F.

PACKING BOX COVER

With Packing - Shell Alvania #71012 Grease Jacketed Packing Box Cover is recommended for temperatures above 250°F.

Driver and Coupling:

See manufacture's recommendations.

PACKING BOX: Packing must be continuously lubricated. Packed pumps are normally furnished less an external recirculation line. When operating with suction lift and clean liquid, recirculation from the pump discharge to the packing box (or suitable grease) may be used. When lubrication is supplied from an outside source, it should be cool, clear water, recommended grease, or a compatible lubricating fluid.

SINGLE SEAL: Pumps with single seals are normally furnished with an external recirculation line. A portion of the liquid being pumped is recirculated from the casing through the seal chamber to serve as a lubricant and coolant.

An alternate method is to supply a cool, compatible lubricating liquid from an outside source to the seal chamber at a pressure of 15 to 25 psi higher than suction pressure.

DOUBLE SEAL: On double seal applications, the seal chamber must be filled with clear, compatible lubricating liquid under pressure. The liquid may be from an outside source or may be from the pump discharge passing through a filter and/or heat exchanger when necessary. Pressure on the box must be 15 to 25 psi higher than suction pressure. The liquid must circulate through the outlet and a restriction must be placed in the outlet to assure pressure on the seal chamber.

If pressurized liquid is not available, Shell Alvania EPRO #71030 grease may be used with pressurized grease cup in limited applications.

3. IMPELLER ADJUSTMENT

An outstanding feature of this pump is the axial adjustment of the impeller to compensate for eventual wear or corrosion. Correct impeller adjustments will insure optimum operating performance and efficiencies.

To adjust impeller clearance:

- a. Disconnect power supply to the driver.
- b. Loosen the three lock nuts and jack screws (204) and (286) then tighten the three cap screws (213) evenly, by alternating cap screws, until the impeller vanes just rub against the casing (1) when the shaft is rotated by hand. It may be necessary to bump the shaft on the coupling end to make sure that the impeller is against the casing.
- c. Alternate tightening the jack screws (286) until they are finger tight against the end face of the frame (19), then loosen cap screws (213).

NOTE: The face of the bearing housing flange (33) must be parallel with the end face of the frame (19) during this adjustment and at the final adjustment. This space should be checked at 90° increments using blocks or suitable gauges. The space should be approximately 5/15" on Fig. 3062 and 3065 frames and approximately 3/8" on Fig. 3066 frame.

- d. Alternate tightening the jack screws (286) as follows:
For ductile iron pumps - an additional 1/4 turn (1 hex) to obtain .006" to .008" clearance between the impeller vanes and the casing.

For alloy pumps - an additional 1/2 turn (2 hex) to obtain .016" to .020" clearance between the impeller vanes and the casing. This clearance may be measured with feeler gauge through suction inlet of the casing or with the impeller against the casing, use two dial indicators against the bearing cover (37) to set the impeller clearance.

- e. Carefully tighten cap screws (213) and lock nuts (204) then rotate shaft by hand to make certain that impeller does not rub against casing.
- f. Place pump in operation and check the power required with a watt-meter to be certain the impeller does not rub the casing.

4. PACKING BOX CARE

Before installing new packing, clean the packing box and inspect parts for wear. If shaft sleeve (14) or pump shaft (6) is worn it should be replaced as packing will not seal against a worn surface.

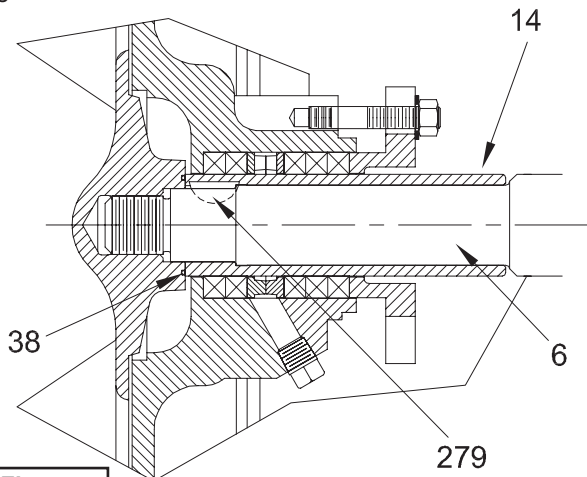

Figure 5

Die molded packing rings are preferable. Twist rings sideways when installing. DO NOT pull rings straight out over the shaft.

Insert two new rings of packing and tamp in place. Stagger joints to minimize leakage. Insert the lantern ring (29), includes two half rings, then add three more rings behind the lantern ring, staggering the joints. Replace gland (17) and tighten nuts (210) to seat packing and rotate pump shaft (6) several times, then loosen nuts to "finger tight" for pump start-up. Be sure that the lantern ring is positioned to receive lubrication through inlet.



IMPORTANT! - Liquid being pumped should drip slowly but constantly through the packing and gland. This will prevent overheating, high power consumption, and shaft sleeve damage.

If packing replacement becomes frequent:

- Check pump bearing for excessive wear causing shaft run-out.
- Check packing for proper grade. Also check whether special packing is used. All iron pumps include Graphite impregnated non-asbestos packing; stainless steel pumps include Teflon impregnated white non-asbestos packing.
- Check shaft sleeve for excessive wear or scoring.
- Check for crystallization of the solution and for embedded abrasives in the packing. Method of packing lubrication may not be satisfactory.
- Check recirculating line, if used as well as relevant fittings, for partial or full blockage.

For care of mechanical shaft seals, see LUBRICATION.

5. DISASSEMBLY

Due to "back pull-out" construction of these pumps, the frame (19) and rotating assembly may be removed from the unit for inspection or service without removing the casing (1) or the driver from the baseplate or piping to the casing.

The disassembly instructions apply to the series of pumps in general and may vary slightly on special units. If complete disassembly is not necessary, use only those steps which apply.

Close gate valve in discharge and suction piping. Inspect all parts removed to determine whether suitable reuse. It is recommended that all packing, gaskets and o-rings be replaced with new ones during reassembly.

NOTE: Special precautions must be observed when handling mechanical seals so as not to damage the lapped faces of the seal.

- Disconnect and remove all cooling or lubricating piping from the pump.
- Remove spacer segment from flexible shaft coupling per manufacturer's instructions.
- Remove cap screws (277) from frame foot (274) and casing cap screws (212) or nuts (249). Remove frame (19) assembly from casing and frame foot. Remove casing gasket (73).
- Unscrew impeller (2) by turning counter clockwise while holding the shaft at the coupling end with a wrench. Remove shaft gasket (38).
- Remove hex nuts (210) and gland clips (206) and remove split gland (17) when pump is fitted with packing (13). If pump has mechanical shaft seal (89) remove hex nuts (210) and carefully slide seal gland (251) with seal seat away from packing box cover (11).
- Remove the packing box cover from frame (19). Packing (13) and lantern (29) may now be removed.

If pump includes single mechanical shaft seal (89) scribe a mark at the seal retainer (230) or spring retainer on the shaft sleeve (14) or shaft to aid in reassembly. Remove seal gland gasket (259).

- Remove shaft sleeve (14) (slide fit) and key (279) from the pump shaft (6). Seal rotating assembly (89B) and retainer (230) (when furnished) will be removed with the shaft sleeve.
- Remove seal gland with seal and deflector (40) from pump shaft.

TO DISASSEMBLE FRAME ASSEMBLY (19)

- Oil Lubricated Bearings
 - Remove pipe plug (236) and drain oil from frame (19).
 - Remove pump half coupling and key (46) from pump shaft (6), also remove cap screws (213), cap screws (332 not shown) and jack screw with lock out nut (286) and (204) then remove bearing cover (37) from bearing housing (33).

3. Open tangs of lock washer (69) and remove bearing lock nut (22) and the lock washer. Insert a small pry bar at several points under the flange of the bearing housing (33) and carefully force the shaft (6) with oil slinger (51), bearings (16) and (18) and bearing housing (33) from the coupling end of the frame (19).
4. Mark the location of the oil slinger (51) on the shaft (6) then loosen the set screws (195). Press ball bearing (16) and oil slinger from the impeller end of the shaft.
5. With bearing puller, remove bearing housing (33) and bearing (18) from the coupling end of the shaft. Press bearing (18) from the bearing housing. Remove bearing cover o-ring (292) and frame o-ring (232).
6. Push inboard bearing cover (35) with seal (47) from the frame. Press bearing cover seals (47) and (49) from bearing covers (35) and (37). Inspect seals for wear.

6. REASSEMBLY

Clean and inspect all parts, replacing any worn or damaged parts, also replace all gaskets and o-rings. Replace mechanical shaft seal showing worn faces, hardened elastomer or loss of spring tension.

FRAME

A. Oil Lubricated Bearings

- a. Position oil slinger (51) on the shaft to the position marked and tighten set screws (195). Press bearing (16) onto the shaft until inner race is against the shaft shoulder.
- b. Carefully press bearing (18) in the bearing housing (33) until properly seated in bottom of bearing housing. Press bearing housing assembly onto the shaft until the bearing inner race is against the shaft shoulder.
- c. Apply light oil to o-ring (232) and insert in the groove of the frame. Apply light oil to the exterior of the bearing housing (33) then carefully guide the shaft and bearing housing into the coupling end of the frame until the space between the flange of the bearing housing and end of the frame is approximately 5/16" for Fig. 3062 and Fig. 3065, and 3/8" for Fig. 3066.



CAUTION - Do not damage o-ring (232) when inserting the bearing housing (33).

- d. Replace bearing lock washer (69) and bearing lock nut (22) on the shaft. Tighten securely. Bend tangs of lock washer into lock nut.
- e. Press shaft seal (49) into bearing cover (37) with lip of seal extending toward the coupling. Apply light oil to o-ring (292) and insert into groove of bearing cover (37) then position and insert bearing cover into the bearing housing. Replace and tighten cap screws (332 not shown). Replace cap screws (213), jack screws with nuts (286) and (204) and alternate tightening until finger tight. See IMPELLER ADJUSTMENT. Replace key (46) and pump half coupling on the shaft.

- f. Press inboard shaft seal (47) into the bearing cover (35) with lip of the seal toward the bearing. Apply light oil to the shaft and carefully slide the bearing cover assembly over the end of the shaft and press into position in the bore of the frame, also replace deflector (40).
- g. Replace pipe plug (236) and fill oil reservoir as described in Section B item 9, LUBRICATION.

B. Grease Lubricated Bearings

- a. Proceed as above, locating the grease retainer (51) behind the bearing at position marked. Omit reference to o-ring (232) and (292).
- b. Apply fresh grease to the ball bearings (16) and (18) during installation also apply grease to cavity of the bearing cover (37) before installing on the bearing housing. **DO NOT OVER**

GREASE.

Fill chamber 1/3 full.

PACKING BOX COVER (11)

1. Fitted with packing (13)
 - a. Place packing box cover on a bench and insert the shaft sleeve (14) in the cover bore, keyway down. Insert packing (13) as outlined in Section D, item 4. If pump is fitted with solid shaft, a piece of tubing of proper size may be substituted for the shaft sleeve.
 - b. Apply Permatex or Silastic to the end of the shaft sleeve that will seal against the shaft shoulder and slide the entire packing box assembly over the shaft aligning the keyways. Insert key (279) into shaft keyway and press shaft sleeve against shaft shoulder.
 - c. Align packing box cover against the frame (19), with the gland studs (281) in a horizontal position, and press into the flange register of the frame until fully seated.
 - d. Assemble split gland (17) on the shaft and replace gland clips (206) and nuts (210).
2. With Mechanical Shaft Seal

Before installing the shaft seal, clean and inspect all parts for damage or wear. Remove all nicks, burrs and rough areas from the shaft and sleeve (14). Protect the faces of the stationary seal seat and rotating washer during installation. See manufacturer's instructions

NOTE: The seal rotating assembly should be mounted on the shaft sleeve (14) before sleeve is placed on the pump shaft (6). If pump is fitted with a solid shaft, the seal gland (251) and gland gasket (401) should be placed on the shaft and the seal rotating assembly mounted on the shaft before the packing box cover is mounted on the frame (19). See following for seal installation.

- a. Single Seal - Crane Type 1
 1. Apply glycerine to the outer surface of the seal seat and o-ring (89) and carefully press the seal seat into the seal gland (251) until seated.
 2. Carefully slide the seal gland (251) and gland

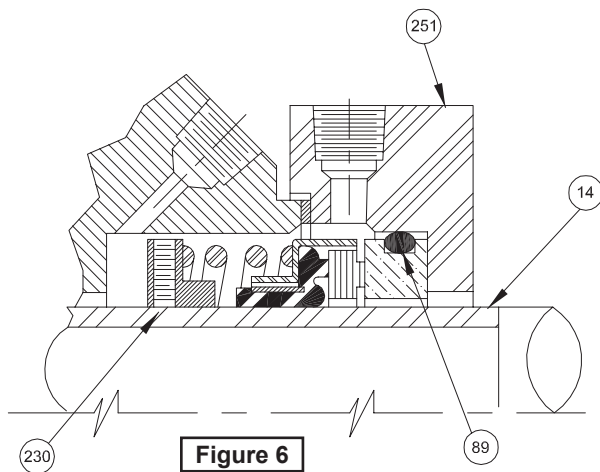

Figure 6
gasket (259) onto the shaft.

3. Apply glycerine to the shaft sleeve (14) or solid shaft (6) and to the inside of the seal bellows. Slide the spring holder (230) onto the shaft sleeve or shaft and position at the scribe mark made previously and tighten set screws. Slide seal rotating assembly onto the sleeve or shaft so that spring is against the spring holder.
4. Apply Permatex or Silastic to the end of the shaft sleeve that will seat against the shaft shoulder, align sleeve keyway and push sleeve with seal assembly onto the shaft. Position gland gasket and seal gland on the sleeve and continue to push sleeve until seated against the shaft shoulder. Replace sleeve key (279) in shaft keyway.
5. Position packing box cover (11) against frame (19) making certain that flange register is fully seated and that lubrication tapings are in the proper position.
6. Position seal gland gasket (259) and seal gland (251) against packing box cover and replace gland nuts (210). Tighten securely.

b. Single Seal - Crane Type 9 - Dura RO and ROTT

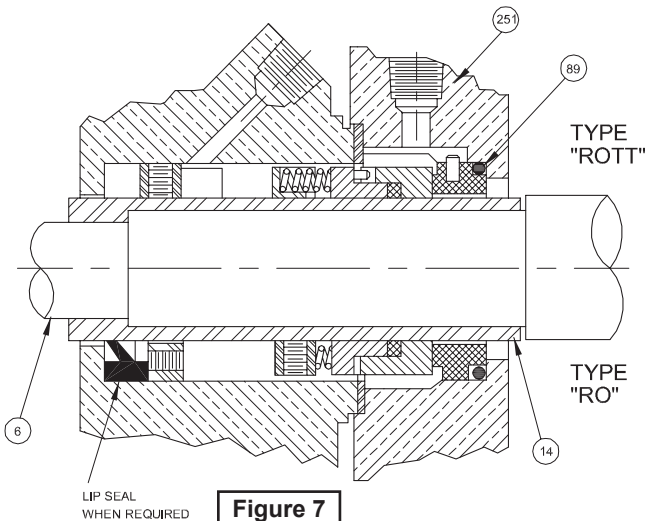

Figure 7

O-ring Mounted Seat

1. Installation is the same as for Type 1 above except seal retainer (230) is not required. Position end of seal spring retainer at

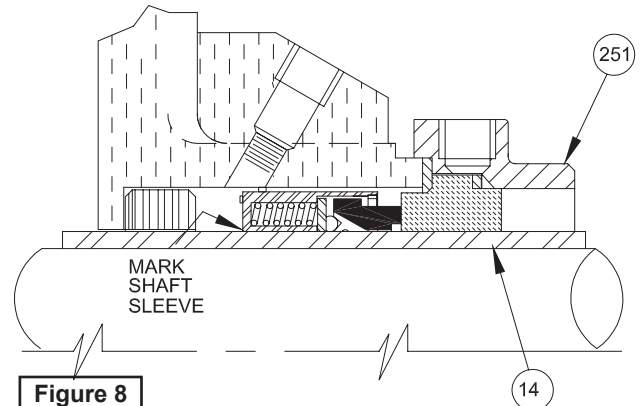

Figure 8

pre-marked position and tighten set screws.

c. Single Seal - Crane Type 9 and Dura RO and ROTT
Clamp Mount Seat

1. Installation is the same as above except that stationary seal seat includes gasket which must

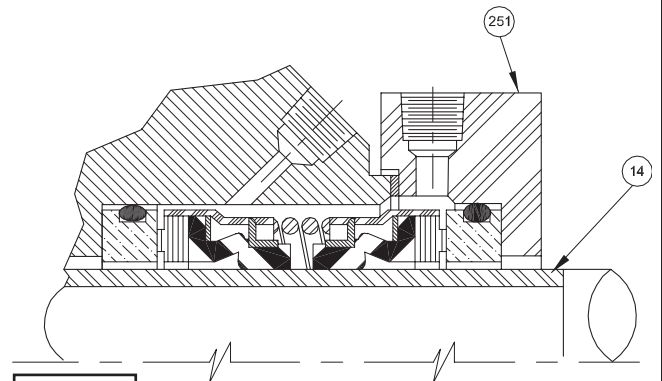

Figure 9

be mounted in the seal gland as shown.

d. Double Seal - Crane Type 1 or Dura CRO

1. Proceed as above for single seal except omit references to seal retainer (230) and install stationary seal seat in seal gland and in the cavity of the packing box cover as shown.

For other types of seals, consult seal manufacturer's

instructions for proper installation.

LIQUID END

- a. Place shaft gasket o-ring (38) in the ring groove of the impeller hub and screw impeller onto the shaft making certain that it is seated against the shaft sleeve or shaft shoulder.
- b. Mount the frame assembly to the casing (1). Insert and tighten cap screws (212). Be sure that the impeller (2) has sufficient clearance to turn freely.

NOTE: Casing (1), packing box cover (11) and frame (19) must be correctly aligned when reassembled. Be sure register flange of packing box cover is fully seated in power frame and that casing is aligned and fully seated on packing box cover BEFORE tightening cap screws (212).

- c. Align frame to frame foot (274) and replace cap screws (277).
- d. Adjust impeller clearance according to Section D, item 3.
- e. Adjust gland pressure and lubricate packing according to Section D, item 4.
- f. Check all lubrication points listed in Section D, item 2.
- g. Replace any tubing or outside piping to packing box cover.
- h. Reassemble flexible shaft coupling and check for pump and motor alignment according to Section B. Verify proper rotation before placing pump in service.

E - LOCATING TROUBLE

1. No Liquid Delivered
 - a. Pump not primed - See Priming
 - b. Speed too low - Check motor speed and nameplate
 - c. Discharge head too high
 - d. Impeller completely plugged
 - e. Wrong direction of rotation - Check wiring
 - f. Suction head too high - over 15 feet, check with vacuum gauge.
 - g. Suction or discharge valves closed
2. Not Enough Liquid Delivered
 - a. Air leaks in suction piping
 - b. Speed too low - Check motor speed
 - c. Discharge head higher than anticipated.
Check discharge valve/system requirements
 - d. Suction lift too high - over 15 feet, check with vacuum gauge.
 - e. Impeller partially plugged
 - f. Wrong direction of rotation
 - g. Not enough suction head for hot liquid
 - h. NPSHA may be too low - pump cavitates
 - i. Mechanical defects
 - j. Air entrainment
 - k. Flow meter improperly calibrated
3. Not Enough Pressure
 - a. Speed too low - Check motor speed
 - b. Air or gas in liquid
 - c. Incorrect impeller diameter - Check system requirements
 - d. Obstruction in pump or piping
 - e. Air leaks in suction piping
 - f. Specific gravity lower than specified - May require larger pump impeller
 - g. Defective pressure gauge
 - h. Mechanical defects
4. Pump Works For A While Then Quits
 - a. Air leaks in suction piping
 - b. Obstruction in pump or piping
 - c. Suction lift too high - over 15 feet, check with vacuum gauge.
 - d. Air or gas in liquid
 - e. Incomplete priming - See Priming
 - f. Air leak due to defective shaft packing
 - g. Air leak through stuffing box when operating with high vacuum or high suction lift. Install recirculation piping or pressurize from outside liquid source.
5. Pump Takes Too Much Power
 - a. Speed too high - Compare Pump and motor nameplates
 - b. Head lower than rating - pumps too much liquid. Check system requirements
 - c. Liquid specific gravity or viscosity greater than expected. Requires large motor.
 - d. Pump and driver misalignment - Check casing for pipe strain. Support piping and realign unit
 - e. Wrong direction of rotation
 - f. Electrical defects - Check power supply and motor
 - g. Impeller oversized for system requirements
 - h. Partial freezing or thickening of liquid when pumped. Check liquid characteristics.
 - i. Mechanical defects
 1. Bent pump shaft.
 2. Impeller binds in casing - Check impeller adjustment
 3. Stuffing box packing too tight. See Packing
6. Excessive Pump Vibration
 - a. Cavitation at pump suction due to insufficient NPSHA. Alter installation to reduce NPSHR
 - b. Impeller out of balance - Check mechanical (static) balance
 - c. Pump and motor misalignment
 - d. Obstruction in pump impeller
 - e. Pump shaft bent
 - f. Worn pump bearings
 - g. Impeller imbalance due to wear or corrosion
 - h. Motor imbalance
 - i. Base plate loose on foundation or insufficient strength to support the load
7. Pump and/or Motor Noise
 - a. Pump and motor misalignment
 - b. Pump cavitation
 - c. Base plate loose or not grouted
 - d. Pump bearings worn
 - e. Motor bearings worn or fan rubs housing
 - f. Foreign matter in pump
 - g. Broken shaft
 - h. Liquid velocity in pump or valves due to greater liquid flow than anticipated.
 - i. Pump impeller imbalance due to wear.

**FIG. 3060 - 3066 - 3068 SERIES END SUCTION
GREASE LUBRICATED with SHAFT SLEEVE**

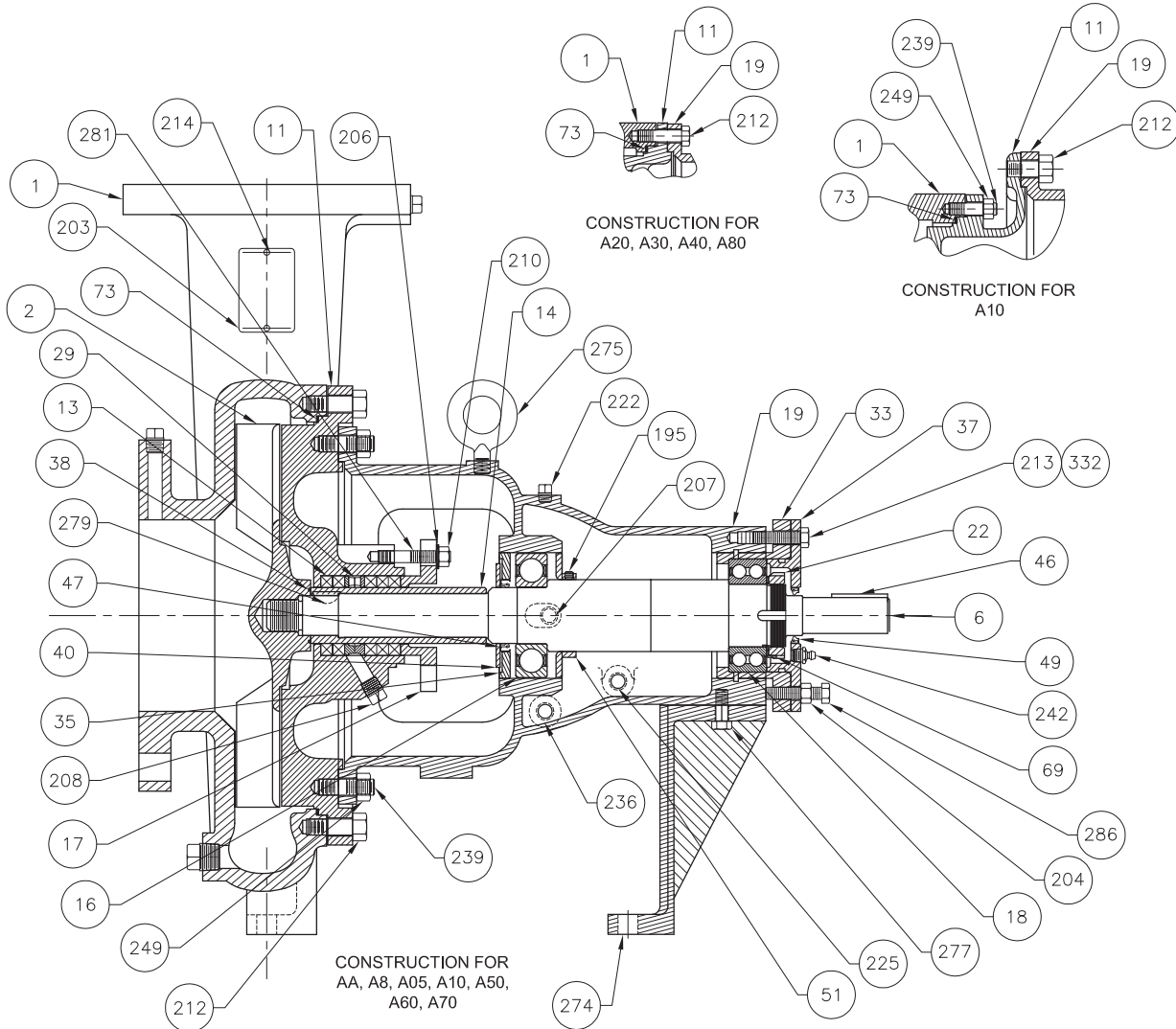

ITEM No.	DESCRIPTION
1	Casing
2	Impeller
6	Shaft
11	Packing Box Cover
13	Packing
14	Shaft Sleeve
16	Bearing (inboard)
17	Gland, Split
18	Bearing (outboard)
19	Frame
22	Nut, Bearing Lock
29	Lantern Ring
33	Bearing Housing - Outboard
35	Bearing Cover - Inboard
37	Bearing Cover - Outboard
38	Shaft gasket
40	Deflector
46	Coupling Key

ITEM No.	DESCRIPTION
47	Bearing Cover Seal - Inboard
49	Bearing Cover Seal - Outboard
51	Grease Retainer
69	Lockwasher, Bearing
73	Casing Gasket
195	Set Screw
203	Name Plate
204	Adjusting Locknut
206	Split Gland Clip
207	Grease Fitting
208	Pipe Plug
210	Nut
212	Cap screw
213	Cap Screw
214	Drive screw
222	Pipe Plug
225	Pipe Plug

ITEM No.	DESCRIPTION
236	Pipe Plug
239	Stud
242	Grease Fitting
249	Hex Nut
274	Frame Foot
275	Lifting Ring
277	Cap screw
278	Caution Label
279	Shaft Sleeve Key
281	Gland Stud
286	Jack Screw (Bearing Cover)
293	Bearing Nameplate (Not Shown)
332	Cap Screw

**FIG. 3060 - 3066 - 3068 SERIES END SUCTION
OIL LUBRICATED with SHAFT SLEEVE**

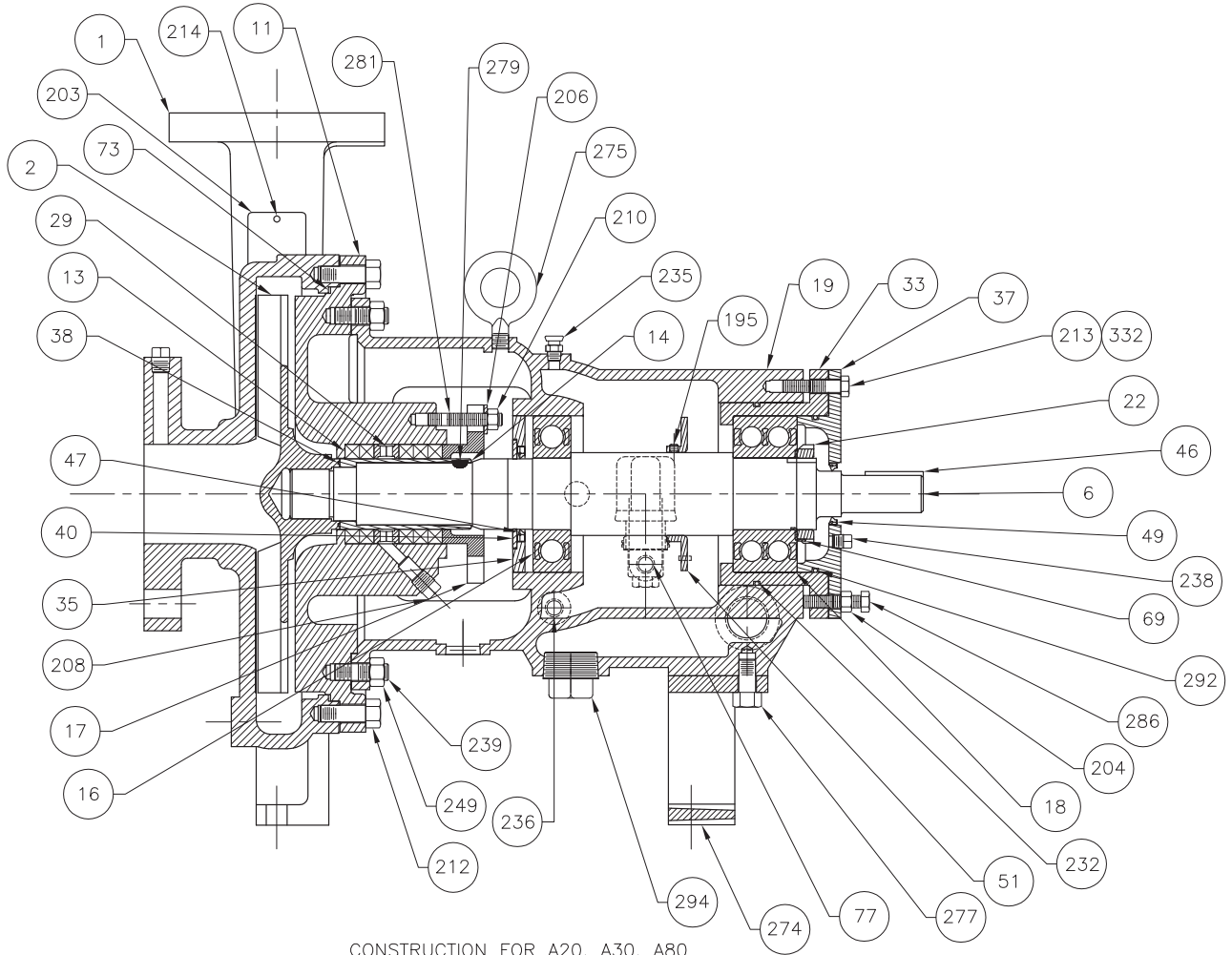

CONSTRUCTION FOR A20, A30, A80

ITEM No.	DESCRIPTION
1	Casing
2	Impeller
6	Shaft
11	Packing Box Cover
13	Packing
14	Shaft Sleeve
16	Bearing (inboard)
17	Gland, Split
18	Bearing (outboard)
19	Frame
22	Nut, Bearing Lock
29	Lantern Ring
33	Bearing Housing - Outboard
35	Bearing Cover - Inboard
37	Bearing Cover - Outboard
38	Shaft gasket
40	Deflector
46	Coupling Key

ITEM No.	DESCRIPTION
47	Bearing Cover Seal - Inboard
49	Bearing Cover Seal - Outboard
51	Oil Slinger
69	Lockwasher, Bearing
73	Casing Gasket
77	Lubricator
195	Set Screw
203	Name Plate
204	Adjusting Locknut
206	Split Gland Clip
208	Pipe Plug
210	Nut
212	Cap screw
213	Cap Screw
214	Drive screw
232	O-ring
235	Breather

ITEM No.	DESCRIPTION
236	Pipe Plug
238	Stud
239	Stud
249	Hex Nut
274	Frame Foot
275	Lifting Ring
277	Cap screw
278	Caution Label
279	Shaft Sleeve Key
281	Gland Stud
286	Jack Screw (Bearing Cover)
292	O-ring (Bearing Cover)
293	Bearing Nameplate (Not Shown)
294	Pipe Plug
332	Cap Screw

**FIG. 3060 - 3066 - 3068 SERIES END SUCTION
OIL LUBRICATED with Shaft Sleeve & Jacketed Packing Box Cooling Frame**

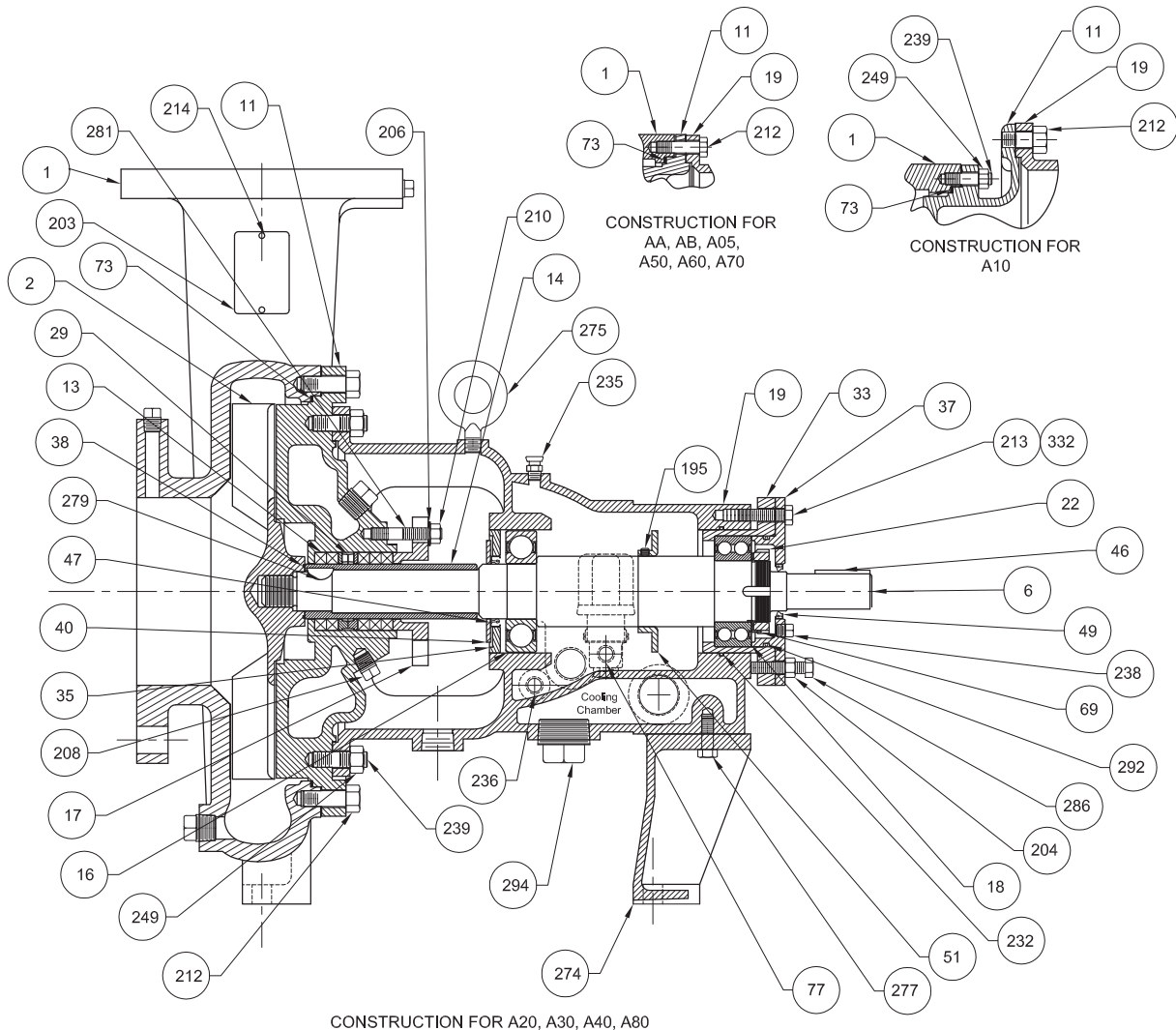

CONSTRUCTION FOR A20, A30, A40, A80

ITEM No.	DESCRIPTION
1	Casing
2	Impeller
6	Shaft
11	Packing Box Cover
13	Packing
14	Shaft Sleeve
16	Bearing (inboard)
17	Gland, Split
18	Bearing (outboard)
19	Frame
22	Nut, Bearing Lock
29	Lantern Ring
33	Bearing Housing - Outboard
35	Bearing Cover - Inboard
37	Bearing Cover - Outboard
38	Shaft gasket
40	Deflector
46	Coupling Key

ITEM No.	DESCRIPTION
47	Bearing Cover Seal - Inboard
49	Bearing Cover Seal - Outboard
51	Oil Slinger
69	Lockwasher, Bearing
73	Casing Gasket
77	Lubricator
195	Set Screw
203	Name Plate
204	Adjusting Locknut
206	Split Gland Clip
208	Pipe Plug
210	Nut
212	Cap screw
213	Cap Screw
214	Drive screw
232	O-ring
235	Breather

ITEM No.	DESCRIPTION
236	Pipe Plug
238	Pipe Plug (Not Shown)
239	Stud
249	Hex Nut
274	Frame Foot
275	Lifting Ring
277	Cap screw
278	Caution Label
279	Shaft Sleeve Key
281	Gland Stud
286	Jack Screw (Bearing Cover)
292	O-ring (Bearing Cover)
293	Bearing Nameplate (Not Shown)
294	Pipe Plug
332	Cap Screw

BARNES®



burks®

WEINMAN®

DEMING®

PROSSER®

Limited 24 Month Warranty

Crane Pumps & Systems warrants that products of our manufacture will be free of defects in material and workmanship under normal use and service for twenty-four (24) months after manufacture date, when installed and maintained in accordance with our instructions. This warranty gives you specific legal rights, and there may also be other rights which vary from state to state. In the event the product is covered by the Federal Consumer Product Warranties Law (1) the duration of any implied warranties associated with the product by virtue of said law is limited to the same duration as stated herein, (2) this warranty is a LIMITED WARRANTY, and (3) no claims of any nature whatsoever shall be made against us, until the ultimate consumer, his successor, or assigns, notifies us in writing of the defect, and delivers the product and/or defective part(s) freight prepaid to our factory or nearest authorized service station. Some states do not allow limitations on how long an implied warranty lasts, so the above limitation may not apply. **THE SOLE AND EXCLUSIVE REMEDY FOR BREACH OF ANY AND ALL WARRANTIES WITH RESPECT TO ANY PRODUCT SHALL BE TO REPLACE OR REPAIR AT OUR ELECTION, F.O.B. POINT OF MANUFACTURE OR AUTHORIZED REPAIR STATION, SUCH PRODUCTS AND/OR PARTS AS PROVEN DEFECTIVE. THERE SHALL BE NO FURTHER LIABILITY, WHETHER BASED ON WARRANTY, NEGLIGENCE OR OTHERWISE.** Unless expressly stated otherwise, guarantees in the nature of performance specifications furnished in addition to the foregoing material and workmanship warranties on a product manufactured by us, if any, are subject to laboratory tests corrected for field performance. Any additional guarantees, in the nature of performance specifications must be in writing and such writing must be signed by our authorized representative. Due to inaccuracies in field testing if a conflict arises between the results of field testing conducted by or for user, and laboratory tests corrected for field performance, the latter shall control. **RECOMMENDATIONS FOR SPECIAL APPLICATIONS OR THOSE RESULTING FROM SYSTEMS ANALYSES AND EVALUATIONS WE CONDUCT WILL BE BASED ON OUR BEST AVAILABLE EXPERIENCE AND PUBLISHED INDUSTRY INFORMATION. SUCH RECOMMENDATIONS DO NOT CONSTITUTE A WARRANTY OF SATISFACTORY PERFORMANCE AND NO SUCH WARRANTY IS GIVEN.**

This warranty shall not apply when damage is caused by (a) improper installation, (b) improper voltage (c) lightning (d) excessive sand or other abrasive material (e) scale or corrosion build-up due to excessive chemical content. Any modification of the original equipment will also void the warranty. We will not be responsible for loss, damage or labor cost due to interruption of service caused by defective parts. Neither will we accept charges incurred by others without our prior written approval.

This warranty is void if our inspection reveals the product was used in a manner inconsistent with normal industry practice and/or our specific recommendations. The purchaser is responsible for communication of all necessary information regarding the application and use of the product. **UNDER NO CIRCUMSTANCES WILL WE BE RESPONSIBLE FOR ANY OTHER DIRECT OR CONSEQUENTIAL DAMAGES, INCLUDING BUT NOT LIMITED TO TRAVEL EXPENSES, RENTED EQUIPMENT, OUTSIDE CONTRACTOR FEES, UNAUTHORIZED REPAIR SHOP EXPENSES, LOST PROFITS, LOST INCOME, LABOR CHARGES, DELAYS IN PRODUCTION, IDLE PRODUCTION, WHICH DAMAGES ARE CAUSED BY ANY DEFECTS IN MATERIAL AND/OR WORKMANSHIP AND/OR DAMAGE OR DELAYS IN SHIPMENT. THIS WARRANTY IS EXPRESSLY IN LIEU OF ANY OTHER EXPRESS OR IMPLIED WARRANTY, INCLUDING ANY WARRANTY OF MERCHANTABILITY OR FITNESS FOR A PARTICULAR PURPOSE.**

No rights extended under this warranty shall be assigned to any other person, whether by operation of law or otherwise, without our prior written approval.

CRANE
®

PUMPS & SYSTEMS

A Crane Co. Company

420 Third Street
Piqua, Ohio 45356
(937) 778-8947
Fax (937) 773-7157
www.cranepumps.com

83 West Drive
Brampton, Ont. Canada L6T 2J6
(905) 457-6223
Fax (905) 457-2650

**IMPORTANT!
WARRANTY REGISTRATION**

Your product is covered by the enclosed Warranty.
To complete the Warranty Registration Form go to:

<http://www.cranepumps.com/ProductRegistration/>

If you have a claim under the provision of the warranty, contact your local
Crane Pumps & Systems, Inc. Distributor.

RETURNED GOODS

**RETURN OF MERCHANDISE REQUIRES A "RETURNED GOODS AUTHORIZATION".
CONTACT YOUR LOCAL CRANE PUMPS & SYSTEMS, INC. DISTRIBUTOR.**



**Products Returned Must Be Cleaned, Sanitized,
Or Decontaminated As Necessary Prior To Shipment,
To Insure That Employees Will Not Be Exposed To Health
Hazards In Handling Said Material. All Applicable Laws
And Regulations Shall Apply.**