

A large industrial fire suppression pumping station. The room is filled with complex machinery, including several large red pumps and a network of red pipes. The pumps are mounted on concrete bases and supported by metal stands. The pipes are connected to various valves and gauges. The overall scene is a well-maintained and functional industrial environment.

# FIRE SUPPRESSION PUMPING

*The Pump People*  
**Patterson**  
A Gorman-Rupp Company



# ABOUT US

Patterson has built a trusted reputation for reliable pump installations worldwide - whether satisfying urban water or waste demands, harnessing and controlling ravaging floods, reclaiming arid deserts, taming rampaging and devastating fires, or protecting the planet's ecological balance, our pumps are trusted.

Around the globe, wherever liquid moves, in large volume or high pressure, you will find Patterson heavy-duty pumps and packaged systems. The world looks to Patterson to enhance safety and comfort in HVAC and fire suppression technology, exceeding pumping demands in water supply, irrigation, flood prevention, and wastewater treatment, make industrial solutions into liquid transfers, and fulfill heating or cooling needs to each of our clients.

All Patterson Fire Pumps and accessories are engineered to meet, or exceed, all applicable codes, including UL listings, FM and NYCBSA approvals and all NFPA-20 standards.

**ISO 14001 and ISO 9001 Certified**

## CHECK US OUT!

**Website**



**Facebook**



**Linkedin**



## SEND US YOUR INSTALLATION PICTURES!

We want to see how it went! Use the QR code to upload your installation pictures. Send us an email afterward to learn how to receive a free gift at [ppc-marketing@pattersonpumps.com](mailto:ppc-marketing@pattersonpumps.com)



\*If you upload to the Dropbox, we reserve the right to use the photos\*



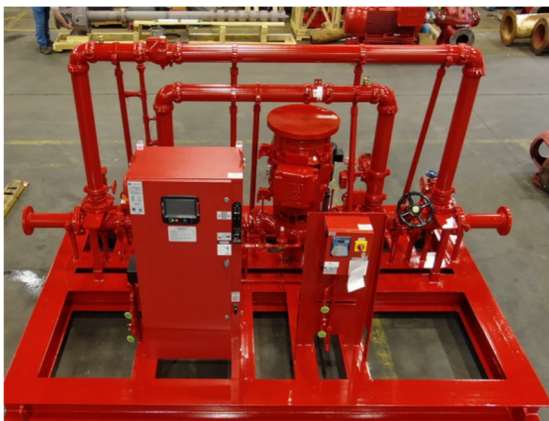
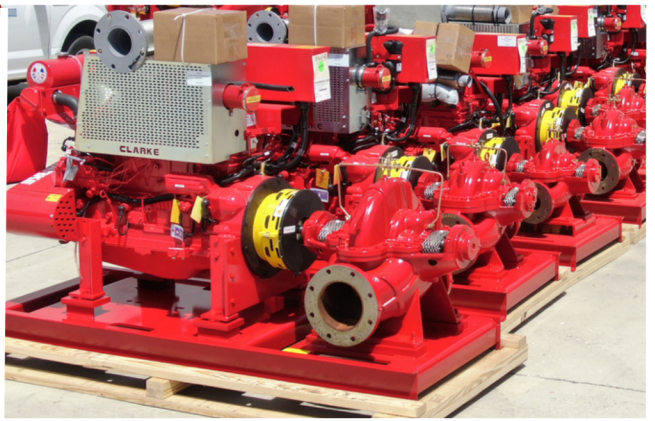

# HORIZONTAL SPLIT CASE

## SINGLE AND MULTISTAGE

Patterson's Horizontal Split Case (HSC) single and multistage line-up of UL Listed/FM Approved fire pumps are the tried-and-true workhorses of the pumping industry. Designed for durability, these pumps lead the world at providing dependable life and property coverage for those who take fire protection seriously.

The rugged single and multiple stage split case designs offer a range of high- and low-pressure pumping while still allowing for in-line service without disturbing piping. All parts are standardized and accurately manufactured to allow for true alignment, balance and increased overall durability. Whether your fire pump application requires an electric motor or a diesel engine, these listed and approved reliable pumps can be configured to meet your specific needs.

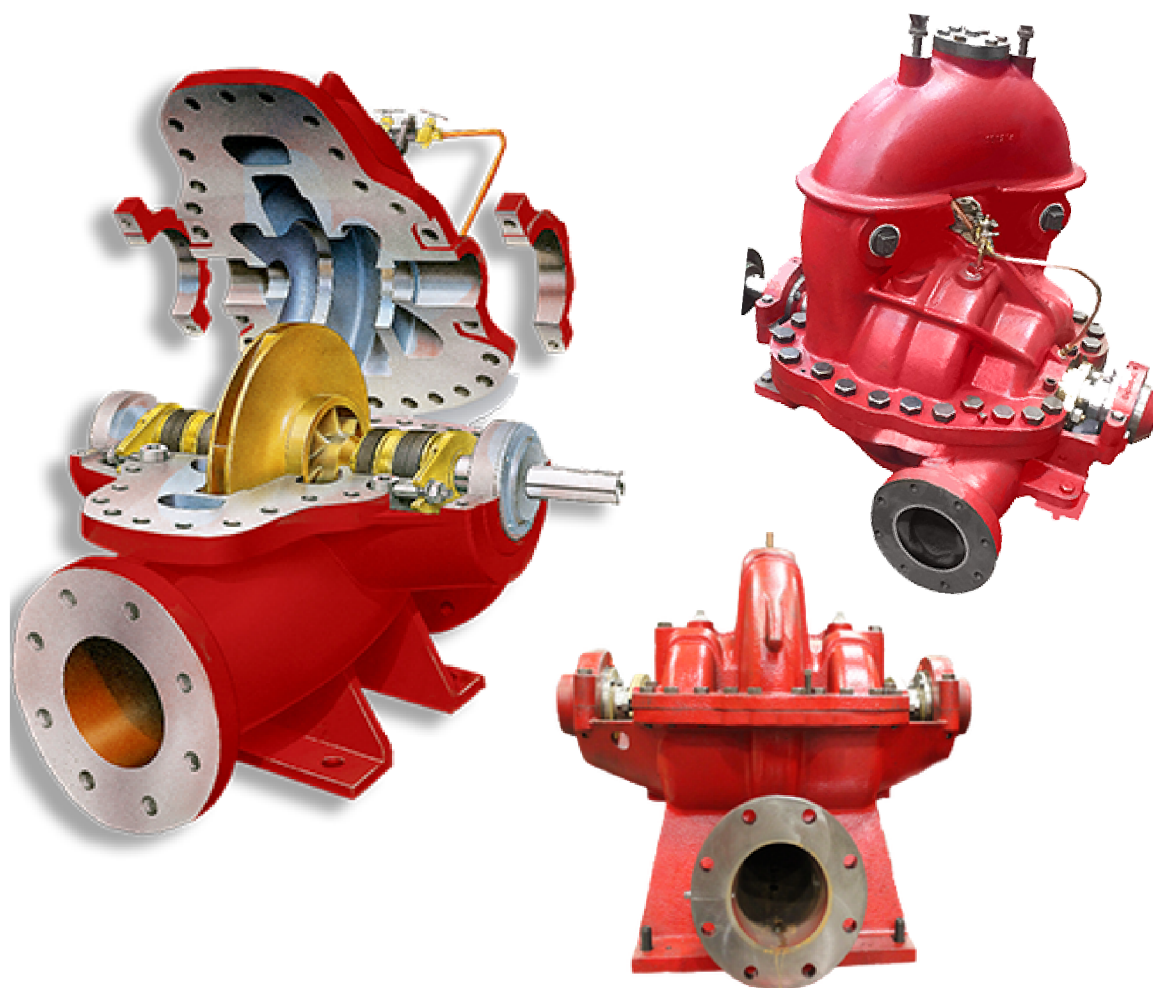

**Horizontal Split Case Operating Specifications: Single/Multiple Stage  
(Diesel Units)**  
offerings at nominal speeds ranging from 3000/2800/2600/2400/2100/1800/1500

Flow (gpm)	Pressure (psi)	Total Head (ft)
300	71-159	164-367
400	67-181	155-418
450	64-179	148-413
500	40-422	92-975
750	40-419	92-968
1000	40-396	92-915
1250	42-247	97-571
1500	49-285	113-658
2000	51-282	118-651
2500	46-234	106-541
3000	80-230	185-531
3500	71-265	164-612
4000	69-262	159-605
4500	66-256	152-591
5000	107-253	247-584

Note: Speeds/conditions may be limited in some regions due to the availability of listed engines which meet emissions requirements.

Horizontal Split Case Operating Specifications: Single/Multiple Stage (Electric Units, 50hz) offerings at nominal speeds ranging from 3000/1500		
Flow (gpm)	Pressure (psi)	Total Head (ft)
400	90-174	208-402
450	87-171	201-395
500	40-422	92-975
750	40-419	92-968
1000	72-396	166-915
1250	90-238	208-550
1500	53-205	122-474
2000	64-191	148-441
2500	88-160	203-370
3000	106-177	245-409
3500	71-229	164-529
4000	69-223	159-515
4500	66-218	152-504
5000	107-209	247-483

Horizontal Split Case Operating Specifications: Single/Multiple Stage (Electric Units, 60hz) offerings at nominal speeds ranging from 3600/1800		
Flow (gpm)	Pressure (psi)	Total Head (ft)
150	45-109	104-252
500	40-565	92-1305
750	40-600	92-1386
1000	40-578	92-1335
1250	42-260	97-601
1500	49-285	113-658
2000	51-282	118-651
2500	46-234	106-541
3000	80-230	185-531
3500	89-265	206-612
4000	98-262	226-605
4500	101-256	233-591
5000	108-253	249-584

**Note: All pump ratings shown are UL Listed/FM approved**



# HORIZONTAL SPLIT CASE

## SINGLE AND MULTISTAGE

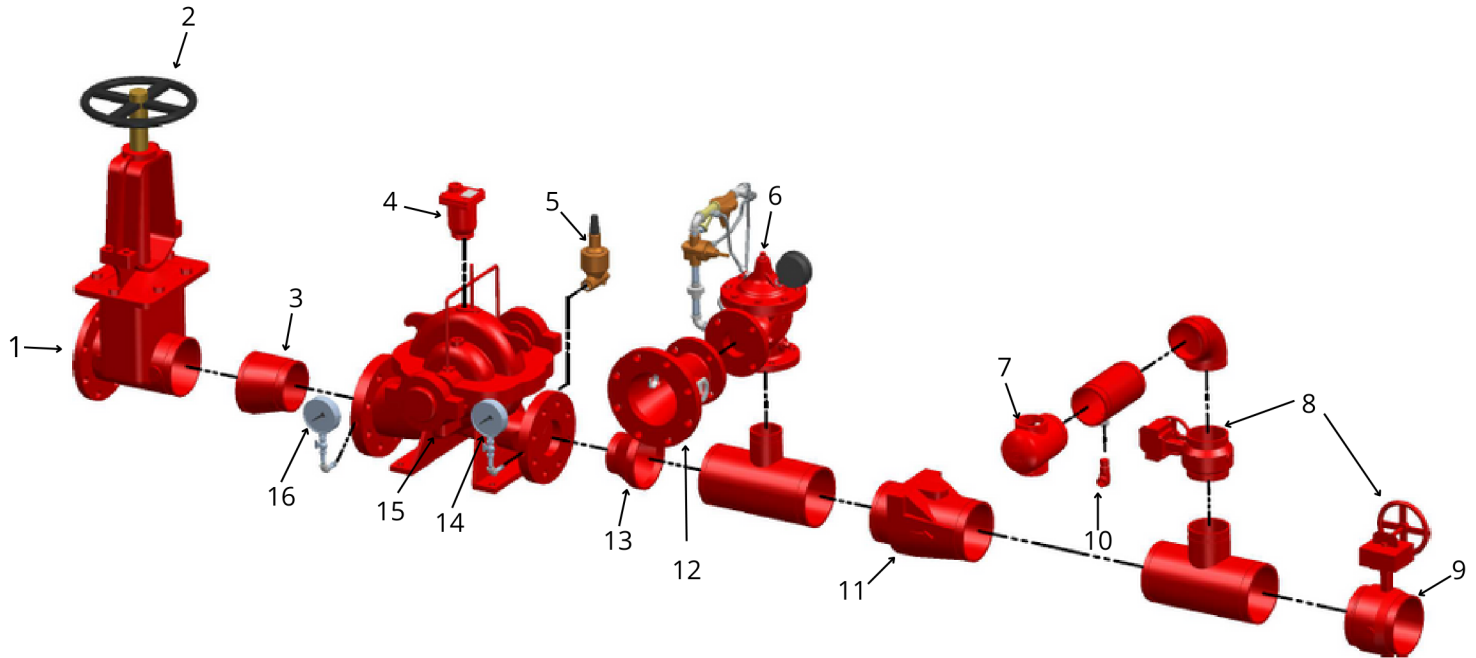

1. From Source

2. OS&Y Gate Valve

3. Eccentric Reducer

4. Air Release Valve

5. Casing Relief Valve

6. Main Relief Valve

7. Hose Valve Header

8. Butterfly/OS&Y Gate Valve

9. To Fire System

10. Drip Valve (To Waste)

11. Check Valve

12. Enclosed Waste Cone

13. Concentric Reducer

14. Discharge Gauge

15. Split Case Fire Pump

16. Suction Gauge

# VERTICAL IN-LINE

## FIRE PUMPS

Patterson's V.I.P. series of Vertical In-Line Fire Pumps offer a simple alternative to horizontal split case pumps in fire applications with lower flow rates. Their unique design also minimizes energy consumption while lengthening service life.

These fire pumps are easy to install into existing pipelines. With the inlet and outlet on a common center line, only standard piping supports on either side of the pump are needed. These pumps are designed with a mounting foot that is compatible with a standard ANSI flange.

Designed for durability, every pump has standard packing and a two-piece gland. Design accommodates a standard JP/JM motor. An integral clean-out port on the suction side enables cleaning without disassembly.



Vertical In-Line Operating Specifications (Electric Units, 50hz) offerings at nominal speeds ranging from 3000/1500		
Flow (gpm)	Pressure (psi)	Total Head (ft)
150	40-150	92-347
200	40-149	92-344
250	40-146	92-337
300	53-146	122-337
400	41-152	95-351
450	43-152	99-351
500	67-151	155-349
750	41-100	95-231
1000	44-95	102-219

Vertical In-Line Operating Specifications (Electric Units, 60hz) offerings at nominal speeds ranging from 3600/1800		
Flow (gpm)	Pressure (psi)	Total Head (ft)
50	40-135	92-312
75	42-134	97-310
100	63-131	146-303
150	45-213	104-492
200	42-212	97-490
250	40-211	92-487
300	50-210	116-485
400	47-181	109-418
450	44-181	102-418
500	41-181	95-418
750	47-148	109-342
1000	40-141	92-326
1250	52-137	120-316

**Note: All pump ratings shown are UL Listed/FM approved**



# VERTICAL IN-LINE

## FIRE PUMPS

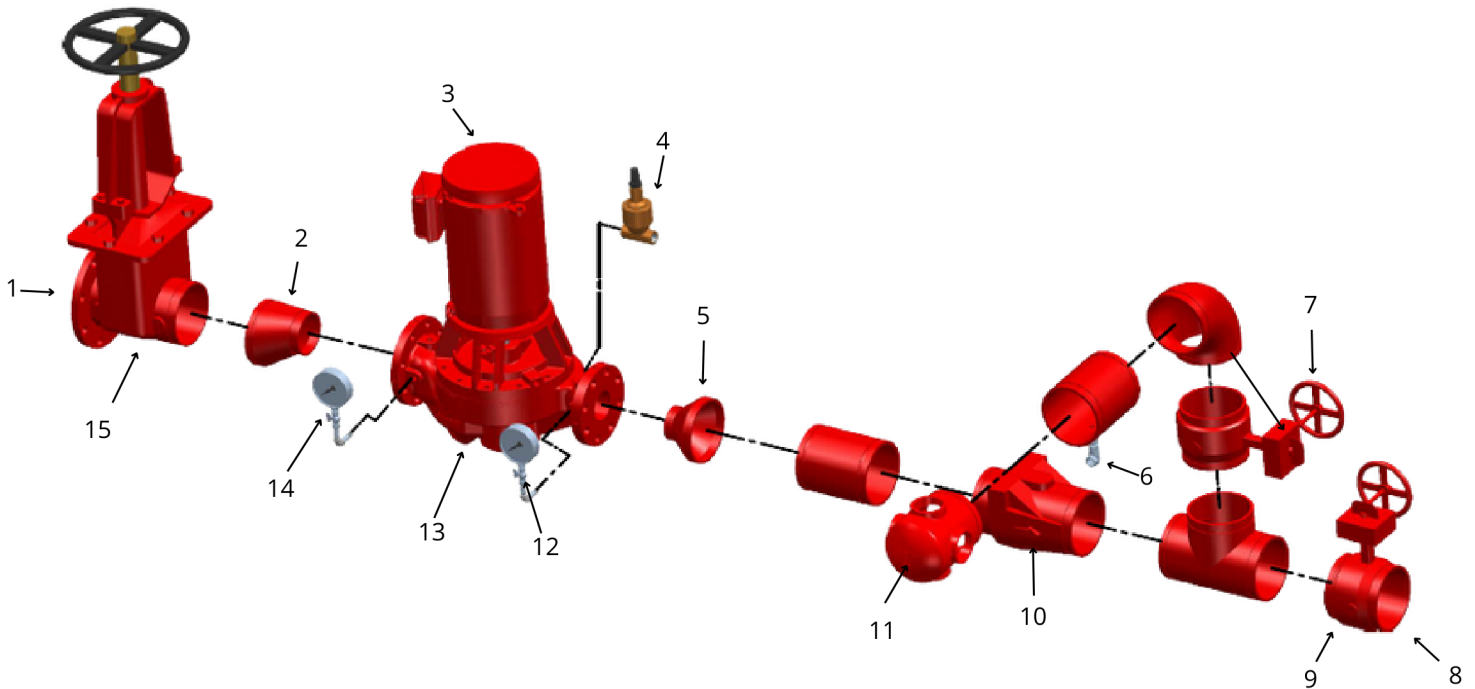

- |                              |                              |
|------------------------------|------------------------------|
| 1. From Source               | 9. Butterfly/OS&Y Gate Valve |
| 2. Eccentric Reducer         | 10. Check Valve              |
| 3. Electric Motor            | 11. Hose Valve Header        |
| 4. Casing Relief Valve       | 12. Discharge Gauge          |
| 5. Concentric Reducer        | 13. VIP Fire Pump            |
| 6. Drip Valve (To Waste)     | 14. Suction Gauge            |
| 7. Butterfly/OS&Y Gate Valve | 15. OS&Y Gate Valve          |
| 8. To Fire System            |                              |

# END SUCTION

## FIRE PUMPS

Some offerings are available in two configurations: frame-mounted or close-coupled, which can be flanged or threaded. These pumps are engineered to last with a precision-cast, dynamically balanced and enclosed impeller that minimizes vibration and maximizes bearing life. Engineered for lasting integrity with standard packing and a shaft sleeve, each unit is hydrostatically pressure-tested to 1-1/2 times shutoff before shipping.

Removing the rotating element without disturbing suction and discharge connections is easy because of our unique, back pullout design. Registered fits at the volute and volute cover maintain pump alignment.

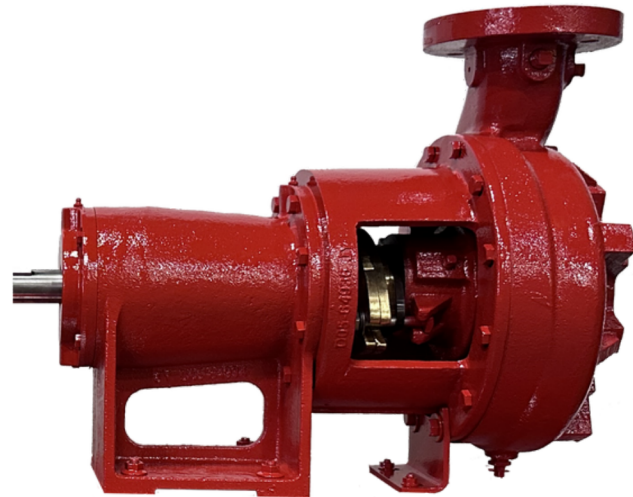

**End Suction Operating Specifications  
(Diesel Units)**

offerings at nominal speeds ranging from 3000/2800/2600

Flow (gpm)	Pressure (psi)	Total Head (ft)
150	40-139	92-321
200	41-138	95-319
250	41-136	95-314
300	48-134	111-310
400	42-148	97-342
450	57-146	132-337
500	65-176	150-407
750	63-151	146-349
1000	118-198	273-457
1250	112-194	259-448
1500	103-187	238-432

Note: Speeds/conditions may be limited in some regions due to the availability of listed engines which meet emissions requirements.

**End Suction Operating Specifications  
(Electric Units, 50 hz)**

offerings at a nominal speed of 3000

Flow (gpm)	Pressure (psi)	Total Head (ft)
150	40-134	92-310
200	40-133	92-307
250	43-132	99-305
300	55-130	127-300
400	57-143	132-330
450	54-141	125-326
500	75-151	173-349
750	83-151	192-349
1000	115-194	266-448
1250	110-189	254-437
1500	100-183	231-423

**End Suction Operating Specifications  
(Electric Units, 60 hz)**

offerings at a nominal speed of 3600

Flow (gpm)	Pressure (psi)	Total Head (ft)
150	55-193	127-446
200	53-193	122-446
250	51-193	118-446
300	62-191	143-441
400	74-209	171-483
450	72-208	166-480
500	69-206	159-476
750	99-147	229-340

**Note: All pump ratings shown are UL Listed/FM approved**

# END SUCTION

## FIRE PUMPS

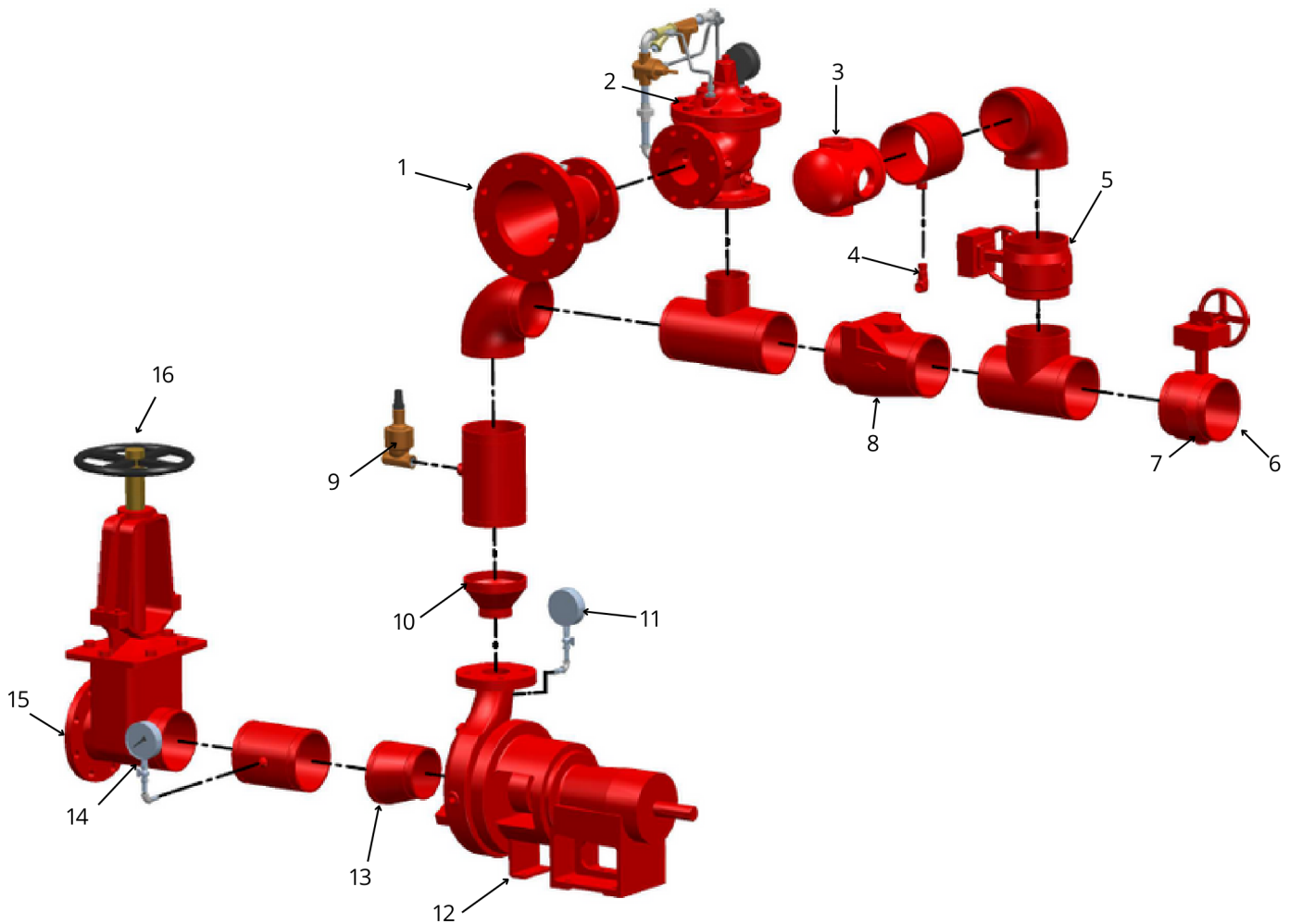

- |                              |                           |
|------------------------------|---------------------------|
| 1. Enclosed Waste Cone       | 9. Casing Relief Valve    |
| 2. Main Relief Valve         | 10. Concentric Reducer    |
| 3. Hose Valve Header         | 11. Discharge Gauge       |
| 4. Drip Valve (To Waste)     | 12. End Suction Fire Pump |
| 5. Butterfly/OS&Y Gate Valve | 13. Eccentric Reducer     |
| 6. To fire System            | 14. Suction Gauge         |
| 7. Butterfly/OS&Y Gate Valve | 15. From Source           |
| 8. Check Valve               | 16. OS&Y Gate Valve       |

# VERTICAL TURBINE

## FIRE PUMPS

Among the most versatile pumps in Patterson's line-up, the Vertical Turbine Fire Pump stands on Patterson's more than 50 years of vertical pump expertise. Employing the latest design concepts and engineering technology, these pumps are ideal for firefighting.

They can be staged as needed to meet specific pressure requirements, with lengths and construction adaptable to the application. And their space-saving vertical design minimizes floor space requirements. Standard construction consisting of cast iron discharge head, flanged steel columns, alloy shafting, and cast-iron bronze fitted bowls. Open line shaft construction is standard; special metallurgies are available.

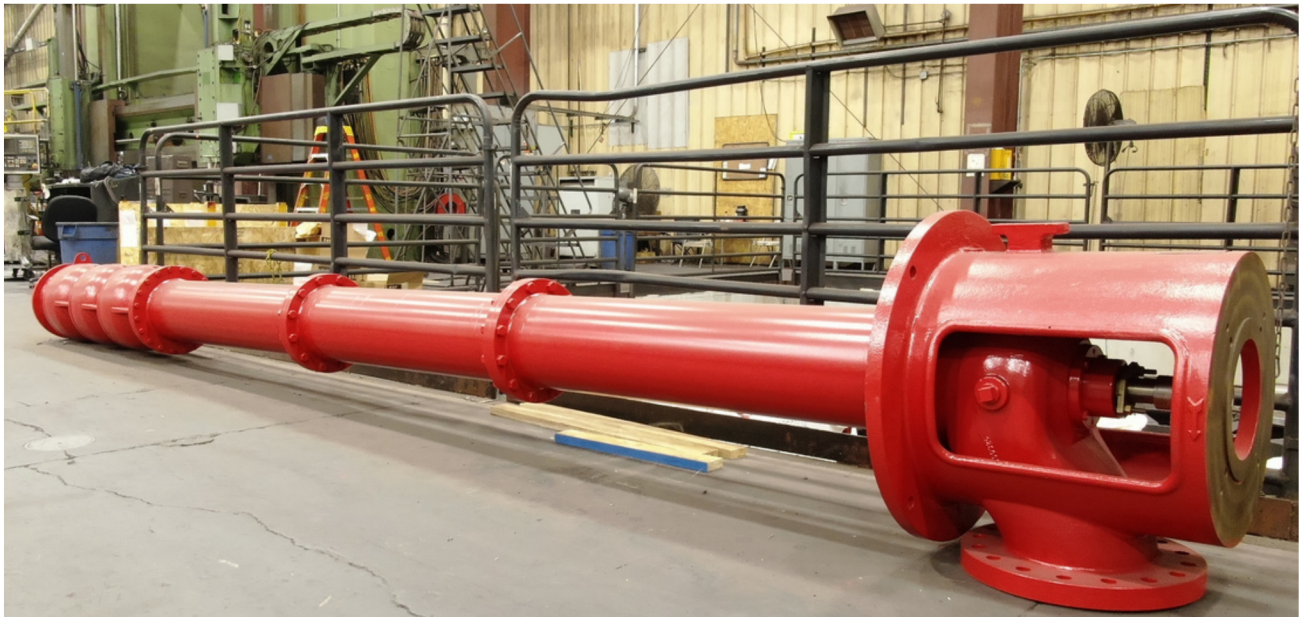

Vertical Turbine Operating Specifications (Electric Units, 50hz and diesel driven) offerings at nominal speeds of 1500		
Flow (gpm)	Pressure (psi)	Total Head (ft)
500	43-277	99-640
750	42-305	97-704
1000	44-272	101-628
1250	47-207	109-478
1500	45-199	104-459
2000	47-196	109-452
2500	60-189	139-437
3000	55-180	127-416
3500	55-126	127-291
4000	74-273	171-631
4500	70-265	162-612
5000	68-255	157-589

Vertical Turbine Operating Specifications (Electric Units, 60hz and diesel driven) offerings at nominal speeds of 1800		
Flow (gpm)	Pressure (psi)	Total Head (ft)
150	43-277	99-640
200	40-264	92-610
250	40-244	92-564
500	59-333	136-769
750	67-403	155-931
1000	80-440	185-1016
1250	78-403	180-931
1500	70-247	162-571
2000	64-281	148-649
2500	67-280	155-647
3000	55-285	127-658
3500	107-271	247-626
4000	78-233	180-538
4500	115-177	266-409
5000	108-160	249-370

Note: Speeds/conditions may be limited in some regions due to the availability of listed engines which meet emissions requirements.

**Note: All pump ratings shown are UL Listed/FM approved**

# VERTICAL TURBINE

## FIRE PUMPS

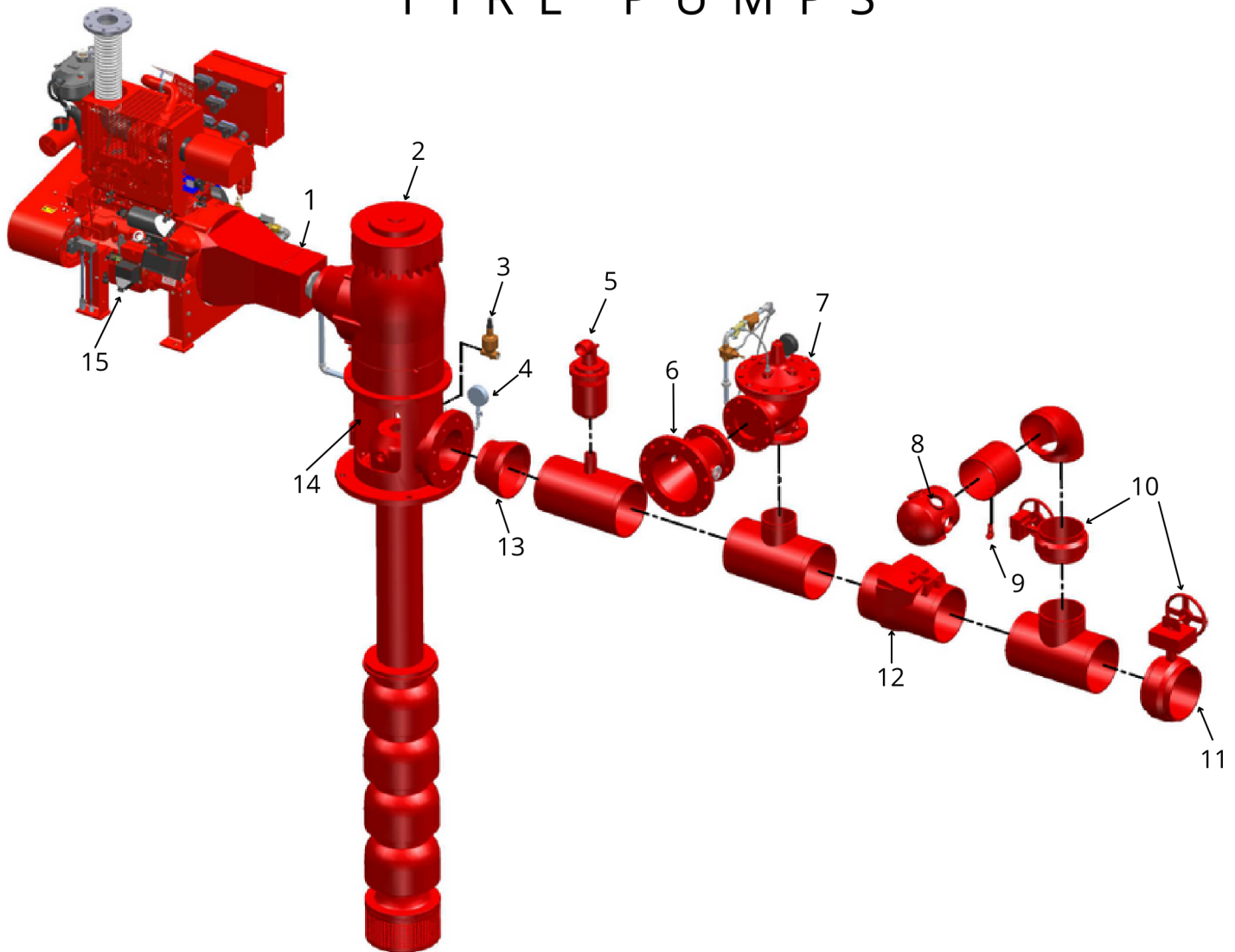

1. Drive Shaft with Guard
2. Right Angle Gear or Electric Motor Drive
3. Case Relief Valve
4. Discharge Gauge
5. Air Release Valve
6. Enclosed Waste Cone
7. Main Relief Valve

8. Hose Valve Header
9. Drip Valve (To Waste)
10. Butterfly/OS&Y Gate Valve
11. To Fire System
12. Check Valve
13. Concentric Reducer
14. Vertical Turbine Fire Pump
15. Diesel engine

# PRE-PAC SYSTEMS

## FIRE PUMPS

The Patterson Pre-Pac is one of the most popular and reliable, self-contained fire protection pump systems on the market today. It is compact, highly efficient, and cost effective. From high-density residential complexes to industrial and commercial sites, the Pre-Pac helps you properly protect the lives and property in your care even while facing budget constraints and space limitations.

Created to provide highly efficient, quality fire control in less space and for less costs. Each Pre-Pac is built in our environmentally controlled facility to your exact specifications. Our knowledge, expertise and complete line of quality fire pumps and accessories ensures that your Pre-Pac system will provide the very best in pumping technology when you need it. We can also provide special metallurgies for seawater service.





# PRE-PAC SYSTEMS

## FIRE PUMPS

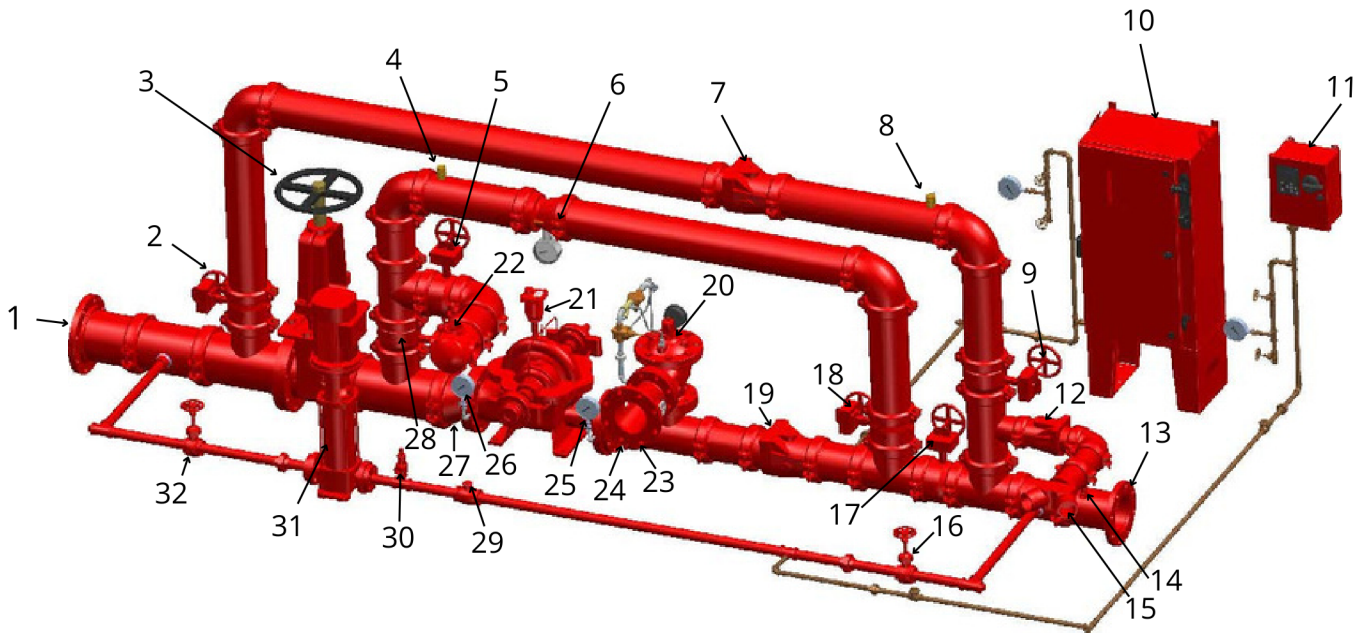

- |                              |                               |
|------------------------------|-------------------------------|
| 1. Suction                   | 17. Butterfly/OS&Y Gate Valve |
| 2. Butterfly/OS&Y Gate Valve | 18. Butterfly/OS&Y Gate Valve |
| 3. OS&Y Gate Valve           | 19. Check Valve               |
| 4. Air Release Valve         | 20. Main Relief Valve         |
| 5. Butterfly/OS&Y Gate Valve | 21. Air Release Valve         |
| 6. Flow Meter                | 22. Hose Valve Header         |
| 7. Check Valve               | 23. Enclosed Waste Cone       |
| 8. Air Release Valve         | 24. Concentric Reducer        |
| 9. Butterfly/OS&Y Gate Valve | 25. Discharge Gauge           |
| 10. Fire Pump Controller     | 26. Suction Gauge             |
| 11. Jockey Pump Controller   | 27. Eccentric Reducer         |
| 12. Check Valve              | 28. Butterfly/OS&Y Gate       |
| 13. Discharge                | 29. Check Valve               |
| 14. Drip Valve (To Waste)    | 30. Pressure Relief Valve     |
| 15. Fire Dept. Connection    | 31. Jockey Pump               |
| 16. OS&Y Gate Valve          | 32. OS&Y Gate Valve           |

# FUEL TANK

## SINGLE WALL

CONSTRUCTED AND LISTED IN ACCORDANCE WITH UL 142

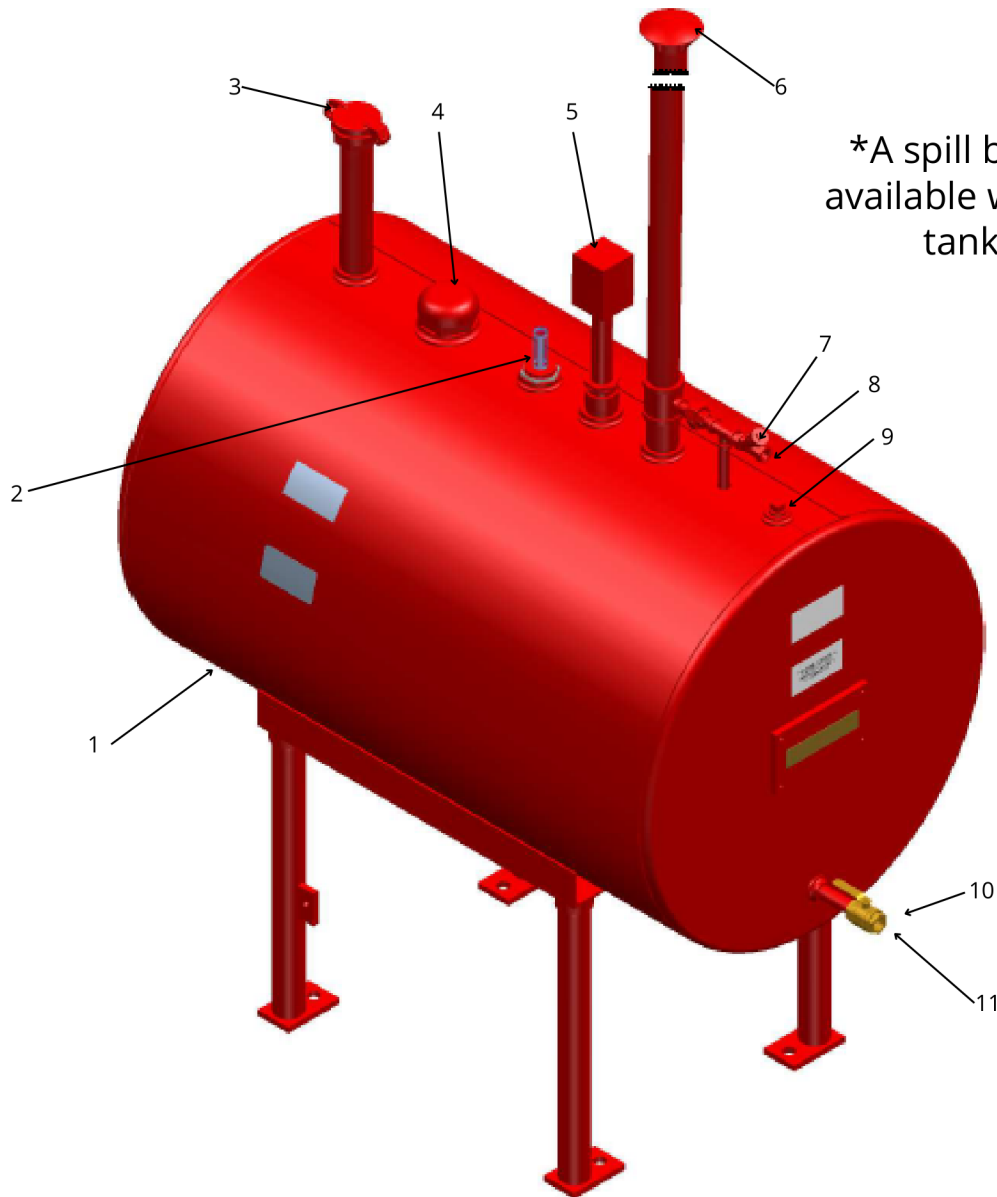

\*A spill basin is available with fuel tanks\*

- |  |   |
|--|---|
| 1. Drain Port 1" NPT w/ Plug                           | 7. Check Valve  |
| 2. Fuel level Indicator Gauge                          | 8. Fuel Return  |
| 3. Tank Fill 2" NPT w/ Lockable Cap                    | 9. 1" NPT Connection w/ Plug<br>(for Use with Fuel maintenance<br>System) |
| 4. Emergency Vent                                      | 10. Ball Valve w/ Locking Device  |
| 5. Low Level Fuel Switch from<br>Controller (optional) | 11. Fuel Supply   |
| 6. Atmospheric Vent 2" NPT                             |   |

# FUEL TANK

## DOUBLE WALL

CONSTRUCTED AND LISTED IN ACCORDANCE WITH UL 142

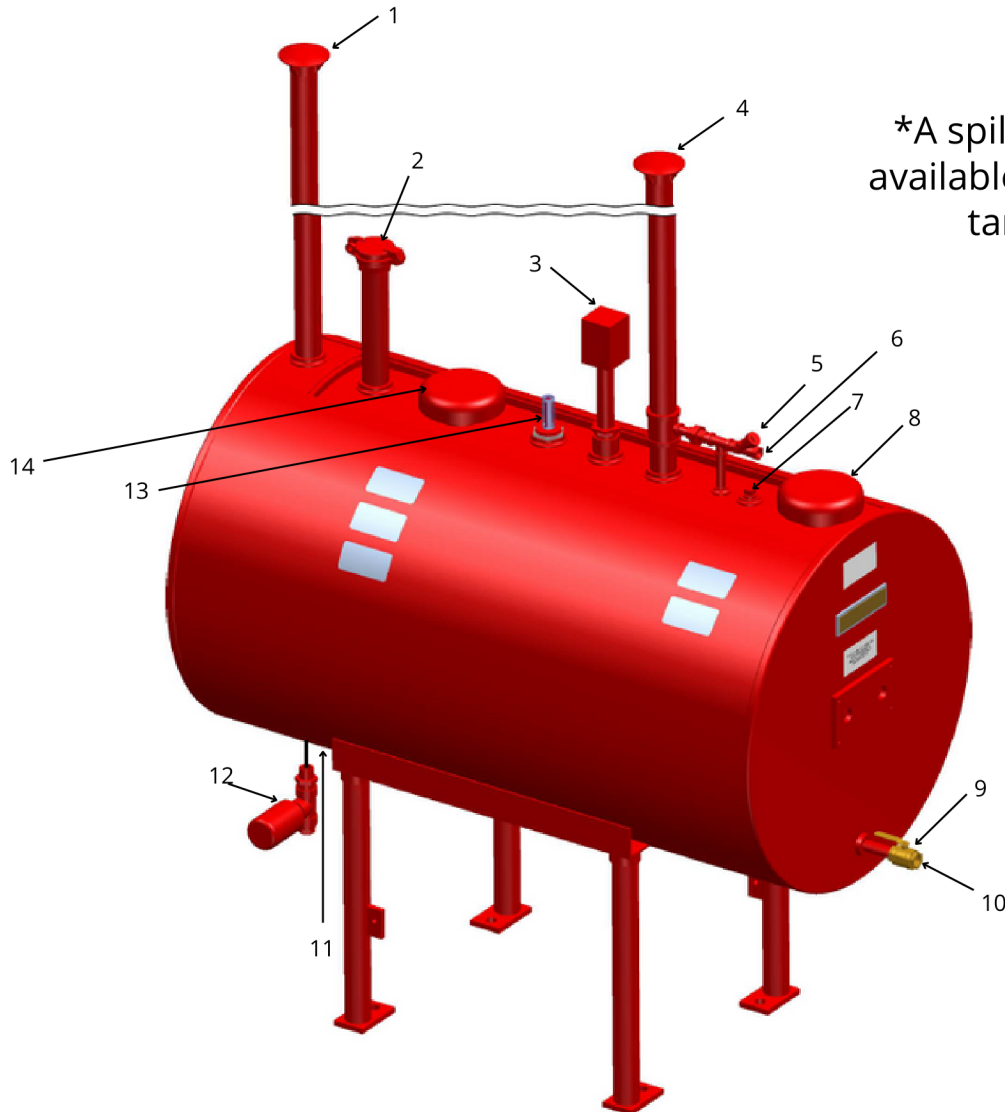

\*A spill basin is available with fuel tanks\*

- |   |                                 |
|---|---------------------------------|
| 1. Atmospheric Vent 2" NPT  | 8. Emergency Vent               |
| 2. Tank Fill 2" NPT w/ Lockable Cap                               | 9. Ball Valve w/ Locking Device |
| 3. Low Level Fuel Switch from Controller (optional)               | 10. Fuel Supply                 |
| 4. Atmospheric Vent 2" NPT  | 11. Drain Port 1" NPT w/ Plug   |
| 5. Check Valve  | 12. Leak Sensor (optional)      |
| 6. Fuel Return  | 13. Fuel Level Indicator Gauge  |
| 7. 1" NPT Connection w/ Plug (for Use w/ Fuel Maintenance System) | 14. Emergency Vent              |

Sales: [ppc-sales@pattersonpumps.com](mailto:ppc-sales@pattersonpumps.com)  
Service: [ppc-service@pattersonpumps.com](mailto:ppc-service@pattersonpumps.com)  
For more information, please visit our website:  
[www.pattersonpumps.com](http://www.pattersonpumps.com)



*The Pump People*  
**Patterson**<sup>®</sup>